

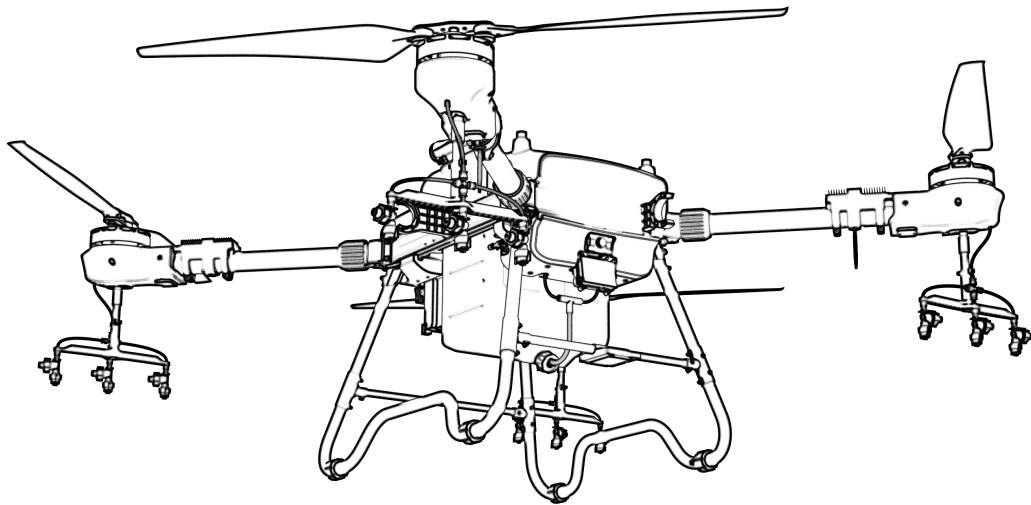

3WWDZ-30.1

Agriculture drone

User Manual V1.2



Topgun (Nanjing) Robotics Co., Ltd.  
2022.2

### **Usage Recommendation**

Topgun provides user with the following documents:

1. "Packing List"
2. "User Manual of Plant Protection UAV FP300"
3. "Usage Guidelines of Agriculture Assistant APP"

For detailed usage and functions, please refer to "User Manual of Plant Protection UAV FP300" and "Usage Guidelines of Agriculture Assistant APP". You can also follow us on YouTube Channel for tutorials and tips in the operation.

\* To keep you updated, some documents may be taken as E-documents.

**User Manual of Plant  
Protection UAV 3WWDZ-30.1**



**Usage Guidelines of  
Agriculture Assistant APP**



**Agriculture Assistant APP**





## **Preface**

The plant protection UAV 3WWDZ-30.1 is a mature multi-rotor aircraft, leading the industry in terms of function, appearance, control, safety and other aspects. There are certain usage risks of multi-rotor drones due to the mechanism and structure. Please strictly follow the safety tips and user manual during the operation. Violation of regulations when using this drone may result in direct or indirect loss and damage.

## **Disclaimer**

Please read the manual carefully before using the aircraft. Once the drone is used, it is deemed to be an acknowledgement and acceptance of all the content of this user manual. This drone is suitable for people 18 years of age and older. Topxgun is not responsible for the loss of personal or property due to the following problems:

1. The user does not assemble or use the drone as required by this manual.
2. The user operates the drone in poor physical or mental conditions such as drinking, drug abuse, fatigue, etc.
3. The user actively or intentionally operates the drone to create damage.
4. The user modifies the drone without using the accessories from Topxgun, which causes malfunction of the drone.
5. Injury caused by the user's misoperation or subjective misjudgment.
6. Damage caused by natural causes, such as aging of the circuit and so on that affects the aircraft.
7. Damage caused by the user's operation of the drone while knowing that it is in an abnormal working condition.
8. The user still operates the drone under severe weather conditions such as typhoons, hail and fog.
9. The user operates the drone in the magnetic interference area, radio interference area and government no-fly area.
10. The user operates the drone in case of poor visibility and occlusion of the line of sight.
11. The user operates the drone to cause the infringements by obtaining any data, image data and other infringement behaviors.
12. Other losses that are not within the scope of the company's liability.

## **Safety operation instructions**

### **1. Pesticide Usage**

- Wear protective clothing to prevent direct body contact with the pesticide while operating.
- Avoid the use of powder pesticides as much as possible or else they may reduce the service life of the spraying system.
- Use clean water to prepare the pesticide to avoid blocking the strainer. Do not remove any filter and clear any blockages before using the equipment.
- After using the pesticide, please clean up the residual liquid in time. It is strictly forbidden to pollute the river and drinking water source and ensure that it will not cause harm or impact on people, animals and the environment in the surroundings.
- The effect of the pesticide is closely related to the concentration of the pesticide, the spraying rate, the altitude of the drone from crops, the wind direction, the wind speed, etc. The above factors should be taken into account comprehensively when using the pesticide in order to achieve the best effect.
- Strictly follow the safety instructions of the pesticide production company.
- Particular working fluids are prohibited.

### **2. Usage Environment**

- Always fly in an open space, away from the crowd.
- It is recommended to fly below 2000 meters.
- It should fly in an environment with a temperature between 0°C and 40°C.
- It is recommended to fly in an environment with a wind speed below level 4.
- It is strictly forbidden to fly in rain, fog, snow or other extreme weather.
- It is strictly forbidden to fly indoors.
- It must fly in a legal area. Before flying in the legal area, please consult your local flight management department to comply with local laws and regulations.

### **3. Pre-flight Inspection**

- Make sure that every device is fully charged.
- Make sure that all parts are in good condition. If there are some parts worn or damaged, please replace them before the flight. Make sure that the landing gear and the tank are tightly mounted and all the screws are firmly tightened.
- Make sure that the propellers are intact and firmly mounted, the propellers and arms are fully extended, and the screws are tightened.
- Make sure the motors are clean and free of damage.
- Make sure the spraying system is free of blockage and works properly.
- Please calibrate the compass before the flight.

#### **4. Operation**

- Keep away from the rotating propellers and motors.
- When folding the drone, avoid crushing and damaging the drone parts.
- Do not exceed the take-off weight of 78.8Kg to avoid danger.
- Pilots must be professionally trained and pass the assessment, and the untrained personnel must not fly the drone.
- Make sure that the propellers are removed before calibrating the drone and upgrading the firmware.
- When the drone and the remote controller are in the frequency-connecting process, make sure that the propellers are removed and that people and animals are far away from the motor.
- A pilot should not operate this product under the influence of alcohol, fatigue, illness, etc.
- If the operating environment does not meet the working condition of the radar module, the drone will not avoid obstacles when it returns automatically. If the remote-control signal is normal, the flight speed and altitude can be controlled using the remote controller.
- When working, be sure to turn on the remote controller first, and then turn on the power supply. After landing, turn off the power supply first and then turn off the remote controller.
- Please maintain control of the drone throughout the process and do not rely entirely on the information provided by the hand-held ground station(remote controller).
- Obstacle avoidance and terrain following functions will not be available in the specific flight mode or environment. Please observe the attitude of the drone at all times and judge the flight condition reasonably to avoid obstacles in time.

#### **5. Flight Restrictions and Local Laws**

- Browse the official website of the Aviation Authority of your location for the latest list of restricted flight areas.
- The maximum control flight altitude is 20 meters. Please consult the local flight management department before taking off, to comply with local laws and regulations.

**Special precautions:** Safety operating instruction notes include but are not limited to the above items.

#### **Intellectual Property Rights**

The intellectual property rights of this product and its manual belong to Topxgun Robotics Co., Ltd. Without written permission, any organization or individual may not copy, reproduce or distribute them in any form. If the quotation is required, the source should be indicated and the manual should not be modified, deleted or quoted contrary to its original intention.

**About this manual**

This manual is used as a user's guide. Photos, graphics, charts and illustrations in the manual are only for explanatory and illustrative purposes and may differ from the actual product. Please refer to the actual product.

Due to product upgrades or other reasons, the content of this document will be updated from time to time. Unless otherwise agreed, it is without further notice.

Before using this product, please read this manual carefully.

Execution standard of this product: Q/TG 001-2018

Copyright.

All rights reserved by Topxgun Robotics Co., Ltd.

## Content

|  |    |
|--|----|
| 1. Product Overview.....                                 | 6  |
| 1.1. Remote Control.....                                 | 6  |
| 1.2. Smart Battery Introduction.....                     | 14 |
| 1.3. Charger Introduction.....                           | 18 |
| 1.4. Drone Introduction.....                             | 24 |
| 2. Flight.....   | 31 |
| 2.1. Flight Instructions.....                            | 31 |
| 2.2. Indicator Description.....                          | 33 |
| 2.3. Operation Description.....                          | 34 |
| 2.4. Function Introduction.....                          | 40 |
| 3. Maintenance and Common Troubleshooting.....           | 49 |
| 3.1. Remote Control Maintenance & Precaution.....        | 49 |
| 3.2. Drone Maintenance & Precaution.....                 | 49 |
| 3.3. Motor Maintenance & Precaution.....                 | 49 |
| 3.4. Propeller Maintenance & Precaution.....             | 49 |
| 3.5. Battery Maintenance & Precaution.....               | 50 |
| 3.6. Plug Maintenance & Considerations.....              | 52 |
| 3.7. Spray System Maintenance & Considerations.....      | 52 |
| 4. Transportation Instructions.....                      | 52 |
| 5. Hazards and Safety Checklist and Countermeasures..... | 53 |
| 6. Manufacturer Information.....                         | 54 |
| 7. Appendix.....   | 54 |
| 7.1. Specification Parameters.....                       | 54 |

## 1. Product Overview

The agricultural drone 3WWDZ-30.1 Agricultural plant protection UAV has undergone several iterations of upgrades, and now reaches the leading level in practicability, reliability and safety. The drone is full-body waterproof, dust-proof and anti-corrosion. Some key modules, such as spraying system, radar system and power system, are IP67 rated ensuring easy cleaning and maintenance. The GNSS+RTK positioning system can achieve centimeter-level high precision positioning, and also supports dual antenna anti-magnetic interference direction-finding technology. The drone is equipped with wide-angle FPV camera and high-definition digital image transmission system. Users can observe the environment in real time.

### 1.1. Remote Control

#### 1.1.1. Component Definition

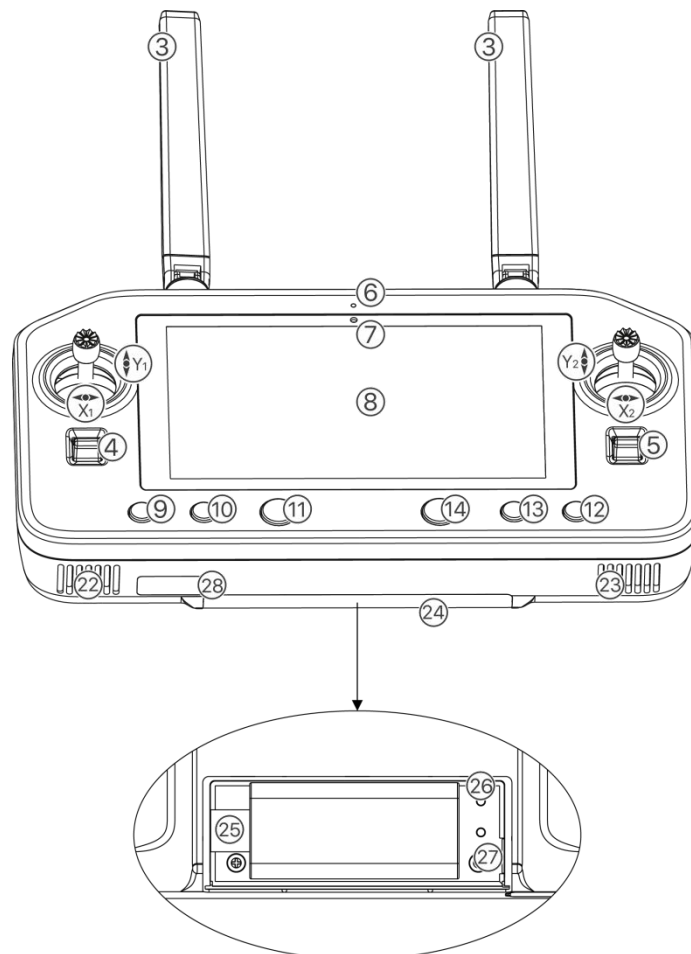



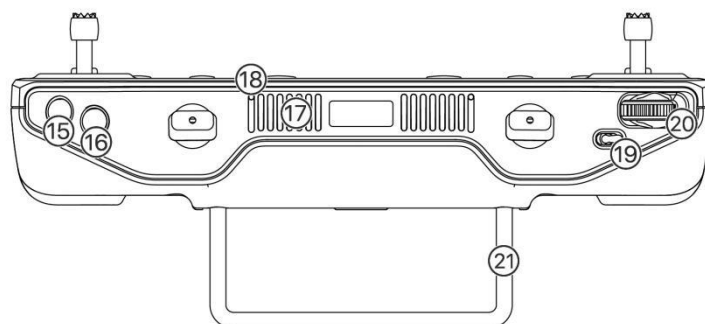

| <b>The main control buttons of the remote control (American hand)</b> |                             |   |   |
|---|-----------------------------|---|---|
| <b>Serial No.</b>   | <b>Corresponding Name</b>   | <b>Corresponding Function</b>                         | <b>Function Description</b>   |
| Y1  | Throttle                    | Left stick -- up and down                             | The drone moves vertically (up and down)  |
| X1  | Yaw                         | Left stick -- left and right                          | The drone rotates (left and right)  |
| Y2  | Roll                        | Right joystick -- left and right                      | Fly left and right  |
| X2  | Pitch                       | Right joystick -- up and down                         | Fly forward and backward  |
| 3   | Remote Control Antenna      | Primary and auxiliary antenna                         | Transit the control signal, telemetry signal, telegraphic signal  |
| 4   | Fine-tuning Button          | Left and right fine adjustment buttons -- up and down | Auto-piloting mode, for adjusting the flight speed and altitude (the firmware is not available in this version) |
| 5   | Fine-tuning Button          | Left and right fine adjustment buttons--up and down   | Auto-piloting mode, for adjusting the flight speed and altitude (the firmware is not available in this version) |
| 6   | Status Indicator            | Remote control status indication                      | Refer to the "Indicator Status" chapter   |
| 7   | Light Intensity Sensor      | Automatic photo --sensitivity                         | Automatically adjust the screen brightness according to the ambient light intensity                             |
| 8   | HD Touch Display            |   | For interface display and touch selection   |
| 9   | AB Point Button             | Short press   | Turn on/off AB point operation mode when the drone is flying.   |
| 10  | Landing Light Button        | Short press   | Turn on/off the landing light   |
| 11  | Power Button                | Long press for 3s to turn on/off                      | Long press to turn the RC on/off. When the RC is on, a short press can be used to turn the screen on/off        |
| 12  | Radar Button                | Short press   | Switch radar on/off   |
| 13  | Pump Button                 | Short press   | Switch pump radar on/off  |
| 14  | RTH (Return-to-home) Button | Long press for 2s, the drone will return home         | Long press the RTH button to activate the smart return mode   |
| 15  | Button A                    | Short press   | Click to record A point   |

|    |                            |                   |  |
|----|----------------------------|-------------------|--|
| 16 | Button B                   | Short press       | Click to record B point  |
| 17 | Air Outlet                 |                   | Do not cover the air outlet of the RC when using   |
| 18 | Microphone                 |                   | Record audio (currently not available)   |
| 19 | Switch Mode Button         | Toggle the switch | Switch between GPS mode and operation mode   |
| 20 | Wheel                      | Toggle            | Spin the wheel to adjust the corresponding signal output, which is only supported in industry applications |
| 21 | RC Handle                  |                   | Convenient for users to hold and carry   |
| 22 | Speaker                    |                   | Output audio   |
| 23 | Air Inlet                  |                   | Do not cover the air inlet of the RC when using  |
| 24 | Wireless Network Card Slot |                   | For installing an external wireless network card   |
| 25 | Wireless Network Card Port |                   | For connecting to wireless network card  |
| 26 | MicroSD Card Slot          |                   | MicroSD card can be inserted   |
| 27 | Rocker Storage Hole        |                   | The RC rocker storage hole   |
| 28 | Charger Interface          |                   | RC charging interface, or connect to PC to update the firmware of the RC                                   |

### 1.1.2. Antenna Placement

The antenna of the RC adopts a foldable design, and the signal strength varies with the positions of the antenna. It is recommended to keep the antenna vertical to the ground when you control the drone. In this case, the signal is the strongest. The position or distance between the RC and the drone is adjusted in time to ensure that the drone is always in the optimal communication range. Therefore, the antenna of the RC should not point to the drone during the flight. The recommended operation is shown in Figure 1-1-3.

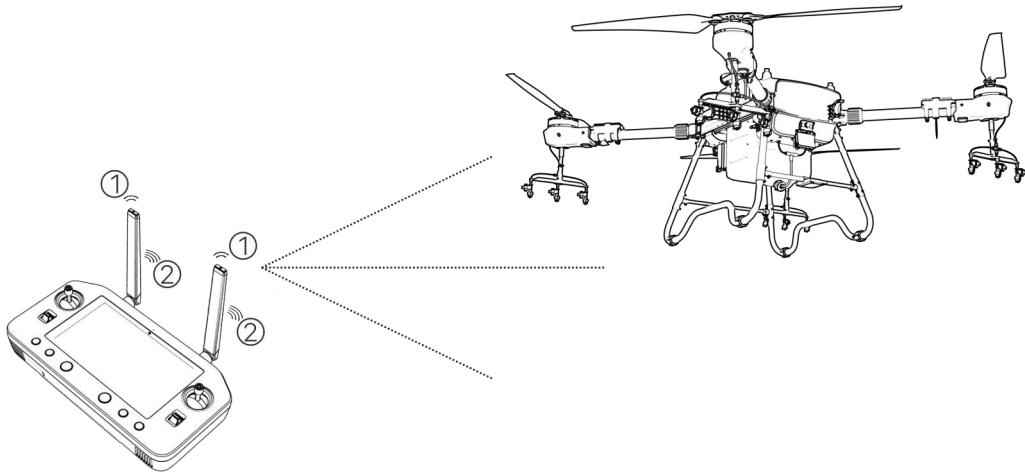

1. Weak signal    2. Strong signal  
 Figure 1-1-3 Signal Strength of the RC

**Notes:**

Do not fold the antenna during the flight to avoid obstruction between the RC and the drone, otherwise, the signal quality will be seriously reduced.

**1.1.3. Indicator Status**

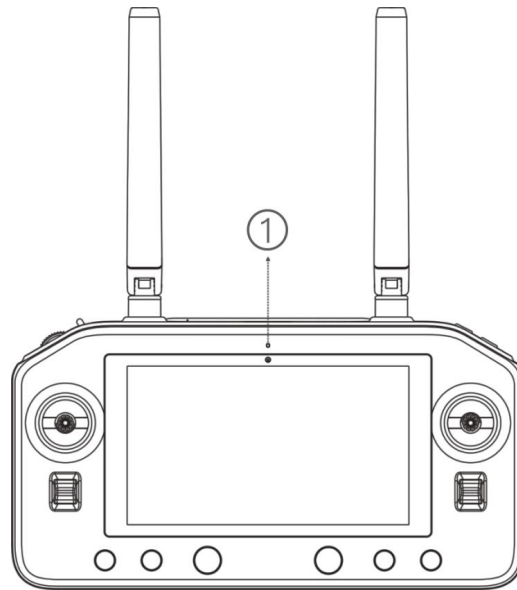

1. Indicator status

The RC status indicator shows the status of the RC.

Details are shown in the table below:

| Indicator Status | RC Status                             | On/Off Status |
|------------------|---------------------------------------|---------------|
| Solid Red        | RC is not connected to the drone      | ON            |
| Solid Green      | RC is connected to the drone properly | ON            |
| Green Flash      | RC is pairing                         | ON            |

|              |   |     |
|--------------|---|-----|
| Green Flash  | RC temperature is too high                            | ON  |
| Red Flash    | RC battery is low                                     | ON  |
| Blue Flash   | The control stick is not in the middle position       | ON  |
| Solid Red    | Charging and the battery level is less than 10%       | OFF |
| Solid Yellow | Charging and the battery level is between 10% and 90% | OFF |
| Solid Green  | Charging and the battery level is over 90%            | OFF |

### 1.1.4. RC Charging

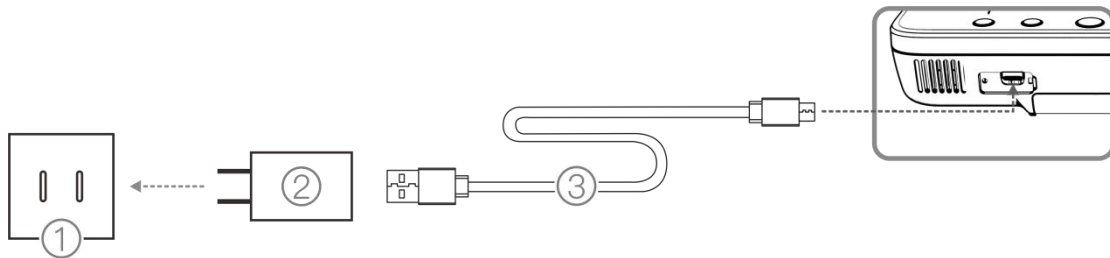

1. AC power supply 100-240V 2. USB charger 3. USB-C cable

#### Attention please:

1. Please use the Type-C interface to charge the RC.
2. Fully charged for about 3.5h with the designated quick charger.
3. Please use the official charger when charging the RC. If not, it is recommended to use an FCC/CE-compliant, 5V 2A charger or a 9V 2A fast charger that complies with the QC2.0 protocol.
4. To ensure the best condition of the battery of the RC, please make sure to fully charge the RC every 3 months.
5. If the RC is found to have a peculiar smell, smoke or liquid leakage, etc., stop charging and send it back for inspection and identification in time.
6. Do not charge the RC when the ambient temperature exceeds 60°C.
7. Keep the RC away from infants' and toddlers' reach while charging. It is recommended not to leave it unattended.

### 1.1.5. Frequency-pairing Instruction

If the user purchases the drone as a whole set, the RC transmitter and the drone have been frequency-paired before dispatching and can be used directly after power-on. In other cases, use the following methods to match the frequency:

1. Turn on the RC parameter adjustment assistant, as shown below

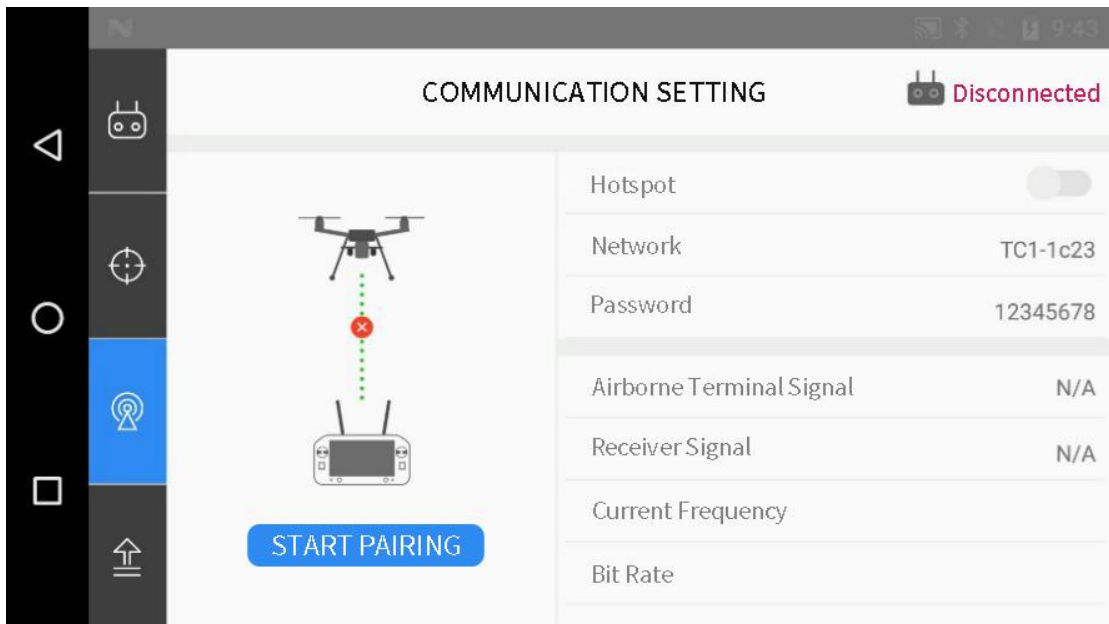

2. Click the “Start Pairing” button, the indicator light of the RC will be flashing green . APP shows a pop-up of “frequency pairing” and there is a 30s time limit to turn on the RC. The receiver turns from green flashing to solid green, and the RC will quickly beep 4 times to show frequency pairing is completed.

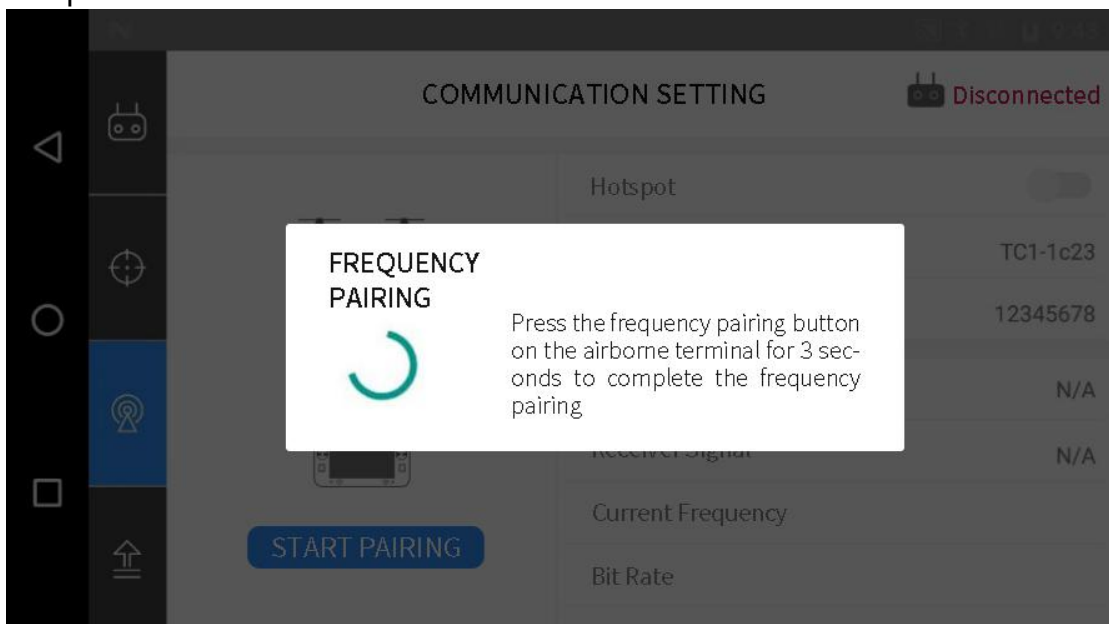

3. Use a sharp tool (e.g. a pen, etc.) to press the frequency pairing button on the airborne terminal for 3s and release it to complete the frequency pairing. After the pairing is completed, the RC indicator will be solid green. If the frequency button is not pressed within 30s, “Frequency Pairing Failed” will be displayed.

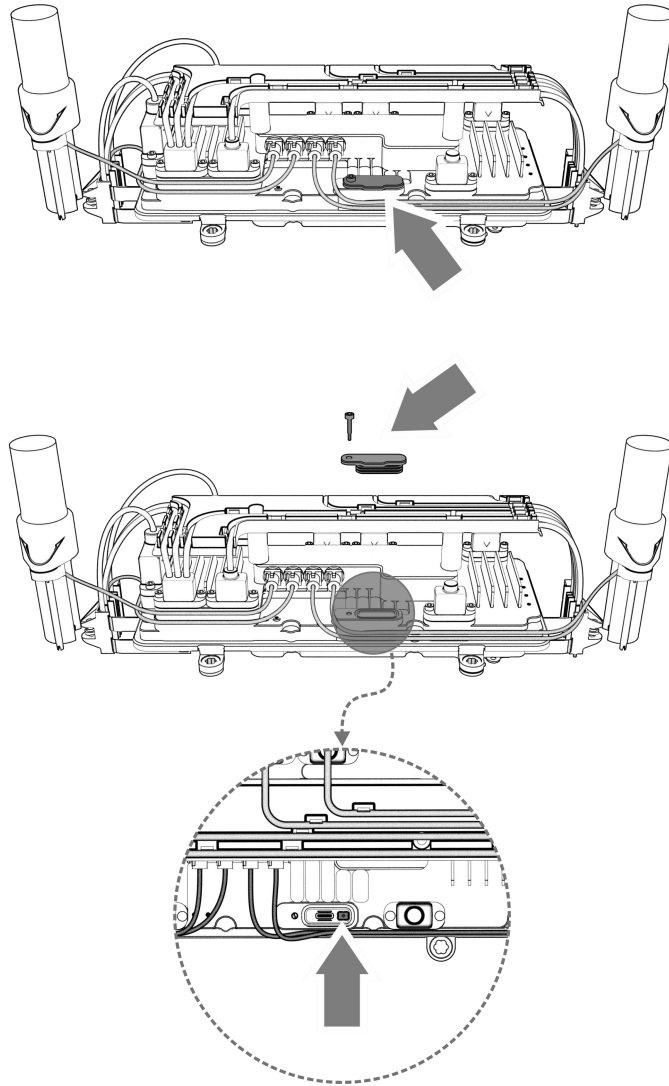

**Notes:**

1. Keep the distance between the RC and the receiver within 1m while pairing.
2. Ensure the propeller is removed from the drone during frequency pairing, and keep a safe distance from drone motors.

**1.1.6. Specification Parameters**

| <b>RC datalink</b>  |   |
|---|---|
| Frequency Range   | 2.4000GHz - 2.4830GHz   |
| Signal Effective Distance<br>(Outdoor, No Obstruction, No Interference) | Maximum communication distance 10km<br>3km image transmission (plant protection scenario) |
| Image Latency   | Less than 70ms  |

|                          |  |
|--------------------------|--|
| Interference Recovery    | <1s                                      |
| Antenna Type             | Omnidirectional antenna (2.5dBi)         |
| <b>Wi-Fi</b>             |  |
| Protocol                 | IEEE 802.11a/n/ac, Wi-Fi compliant       |
| Operating Frequency      | 4.900 GHz ~ 5.845 GHz (5.0 GHz ISM Band) |
| <b>Bluetooth</b>         |  |
| Protocol Standard        | Bluetooth 4.2                            |
| Working Frequency Range  | 2.400-2.4835GHz                          |
| <b>FPV camera</b>        |  |
| Pixel                    | 4 million                                |
| View Angle               | 140° horizontally, 87° vertically        |
| Video Resolution         | 720p                                     |
| FPV Auxiliary Light      | 15lux @5m direct light                   |
| <b>Display</b>           |  |
| Screen Size              | 5.5 inch                                 |
| Touching Mode            | Capacitive                               |
| Screen Color             | 16 million colors                        |
| Screen Resolution        | 1920x1080                                |
| Screen Brightness        | 1000cd/m <sup>2</sup>                    |
| <b>Other Parameters</b>  |  |
| Operating System         | Android OS                               |
| Operating Temperature    | -15°C to 40°C                            |
| Storage Temperature      | -25°C to 60°C                            |
| Charging Temperature     | 5°C to 40°C                              |
| Battery Type             | 12000mAh @3.7V lithium battery           |
| Rated Power              | About 6W                                 |
| Charging Time            | About 3.5h (using official fast charger) |
| Continuous Working Hours | More than 6h                             |
| FPV Camera               | DC 12V, less than 0.5A                   |
| Receiver                 | DC 5V 1A                                 |
| Weight                   | About 750g                               |

## 1.2. Smart Battery Introduction

TB1430 battery is a polymer lithium power battery, featuring a compact size, light weight and large capacity.

### 1.2.1. Component Definition

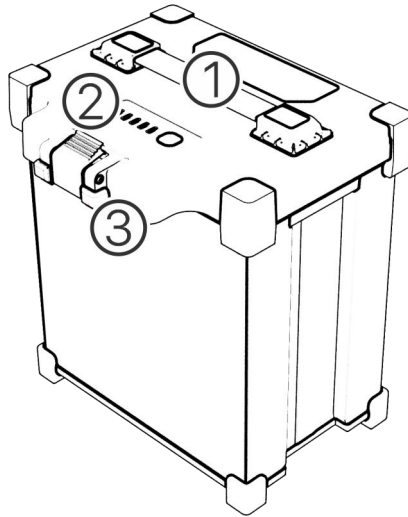

1. Handle 2. Indicator 3. Charging port  
Figure 1-2-1 Battery Component

### 1.2.2. Specification Parameters

| Subject                     | Parameter   |
|-----------------------------|---|
| Typical Capacity            | 30000mAh  |
| Nominal Voltage             | 51.8V   |
| Standard Charging Current   | 150A (Environment Temperature 25±5℃)  |
| Maximum Charging Current    | 15A, cell temperature, 0~10℃<br>30A, cell temperature, 10~15℃<br>150A, cell temperature, 15~70℃ |
| Limited Charging Voltage    | 58.8V   |
| Maximum Discharging Current | 240A, ambient temperature, -5~45℃   |
| Operating Temperature       | 0~45℃ (Charge)<br>-10~60℃ (Discharge)   |
| Storage Temperature         | -20~25℃ (One Year)  |
| Weight                      | 11.0kg  |



### 1.2.3. LED Indicator Status

#### 1.2.3.1. Battery Status Display

| Function               | Precondition  | Operation                                   | LED Indicator   | Note   |
|------------------------|---|---|---|--|
| Battery Level Checking | Sleep/Power off   | 0<br>(Short Press)                          | Display the current battery level for 3s  | The battery level will be displayed for 3s after a short press |
| Power On               | Sleep/Power off   | 0-1<br>(Short Press+Long Press >1s)         | 0, display the current battery level;<br>0-1, turn off the display. The LED indicators will light up one by one, then display the current battery level | 0-1 MOS has been activated after power on                      |
| Power Off              | Power On  | 0-1<br>(Short Press+Long Press)             | 0, display the current battery level;<br>0-1, turn off the display. The LED indicators will go off one by one   | 0-1 MOS has been deactivated after power off                   |
| RC Pairing             | Battery is activated and RC is on the pairing interface | In the power on status 2<br>(Long Press>5s) | The LED 3 and 4 will flash while pairing.<br>After the pairing is completed, LED indicators will revert to the original status                          |  |
| Disconnect UPS         | Battery is activated                                    | Short press for 5 times,<br>0-0-0-0-0       | 0, display the current battery level  | 1. UPS is deactivated  |

#### 1.2.3.2. Battery Level Display

When the battery is in standby mode, short press the power button once to display the current battery level, and it will turn off after 3s.

| Battery Level | LED1  | LED2  | LED3  | LED4  | LED5  |
|---------------|-------|-------|-------|-------|-------|
| 91%~100%      | ON    | ON    | ON    | ON    | ON    |
| 81%~90%       | ON    | ON    | ON    | ON    | FLASH |
| 71%~80%       | ON    | ON    | ON    | ON    | OFF   |
| 61%~70%       | ON    | ON    | ON    | FLASH | OFF   |
| 51%~60%       | ON    | ON    | ON    | OFF   | OFF   |
| 41%~50%       | ON    | ON    | FLASH | OFF   | OFF   |
| 31%~40%       | ON    | ON    | OFF   | OFF   | OFF   |
| 21%~30%       | ON    | FLASH | OFF   | OFF   | OFF   |
| 11%~20%       | ON    | OFF   | OFF   | OFF   | OFF   |
| 0%~10%        | FLASH | OFF   | OFF   | OFF   | OFF   |

### 1.2.3.3. Charging Status

The battery displays the charging status while charging: in the off state, press the power display button once, and then long-press. LED1~LED5 will turn on one by one, and the battery charging status display function is activated.

| Battery Level | LED1  | LED2  | LED3  | LED4  | LED5  |
|---------------|-------|-------|-------|-------|-------|
| 0%~40%        | Flash | Flash | OFF   | OFF   | OFF   |
| 41%~60%       | Flash | Flash | Flash | OFF   | OFF   |
| 61%~80%       | Flash | Flash | Flash | Flash | OFF   |
| 81%~99%       | Flash | Flash | Flash | Flash | Flash |
| 100%          | ON    | ON    | ON    | ON    | ON    |

### 1.2.3.4. Error and Other Indications

The abnormal charging status will trigger the battery protection function and the battery LED light will display as follow.

| <b>Error Info</b>                                 | <b>LED1</b> | <b>LED2</b> | <b>LED3</b> | <b>LED4</b> | <b>LED5</b> |
|---|-------------|-------------|-------------|-------------|-------------|
| Excessive Charging Current                        | OFF         | FLASH       | FLASH       | OFF         | OFF         |
| Excessive Battery Voltage                         | OFF         | ON          | ON          | OFF         | OFF         |
| Charge<br>Overcurrent/Discharge<br>Overcurrent    | OFF         | OFF         | OFF         | FLASH       | OFF         |
| Low Charging Temperature                          | OFF         | OFF         | ON          | OFF         | OFF         |
| High Charging Temperature                         | OFF         | OFF         | FLASH       | OFF         | OFF         |
| Pre-discharge Failed                              | OFF         | OFF         | OFF         | FLASH       | FLASH       |
| Battery Cell Pressure<br>Difference exceeds limit | FLASH       | OFF         | OFF         | OFF         | FLASH       |
| MOS Overheat                                      | OFF         | OFF         | FLASH       | OFF         | FLASH       |
| MOS Error   | OFF         | OFF         | ON          | OFF         | ON          |
| NTC Open Circuit/Short<br>Circuit                 | OFF         | FLASH       | FLASH       | FLASH       | OFF         |
| Connector Overheat                                | OFF         | FLASH       | OFF         | FLASH       | OFF         |
| Collection Line Open Circuit                      | OFF         | ON          | ON          | ON          | OFF         |
| Battery Updating                                  | FLASH       | FLASH       | FLASH       | FLASH       | FLASH       |
| AFE Communication Failure                         | OFF         | FLASH       | OFF         | FLASH       | FLASH       |
| 0V Disabled Charging                              | OFF         | ON          | FLASH       | FLASH       | ON          |
| Short Circuit Protection                          | ON          | FLASH       | FLASH       | FLASH       | ON          |
| CAN Communication Failure                         | ON          | FLASH       | ON          | FLASH       | ON          |

**Notes:**

1. Activate the battery only after it is well connected to the drone.
2. Disconnect the battery after it is turned off.
3. Charge the battery to 60% every 3 months to ensure a longer service lifetime.
4. Before using, ensure sufficient battery level. When the battery has not been used for a long time, please use the dedicated charger to discharge the battery to the storage voltage, and then store it in a dry and ventilated environment.
5. This battery needs to be charged with a dedicated charger (TC7202). In order to avoid accidents, please do not change the charger in any condition.
6. Do not use batteries if they emit odors or heat, or they are in an abnormal shape/color or has any other problems. If the battery is in use or charging, it should be immediately removed from the drone or charger. Stop using this kind of battery.
7. It is normal that the flight time will be shortened when the ambient temperature is lower than 10°C.
8. The battery surface should be cleaned in time after the operation, in order to avoid agrochemical corrosion.
9. The drone is strictly forbidden to be used in the environment of strong static electricity, magnetic field or high voltage power line.

- 10. It is strictly prohibited to pierce the battery case with nails or other sharp objects, or to hammer or step on the battery.
- 11. If the electrolyte enters eyes after the battery leaks, rinse the electrolyte out instead of rubbing the eye. Seek medical help immediately. Eyes will be injured if not treated in time.

**1.3. Charger Introduction**

TC7202 charger is a two-channel lithium-polymer battery charger with a maximum charging current of 150A.

**1.3.1. Components**

The definition of the charger components is shown in Figure 1-3-1 and Figure 1-3-2.

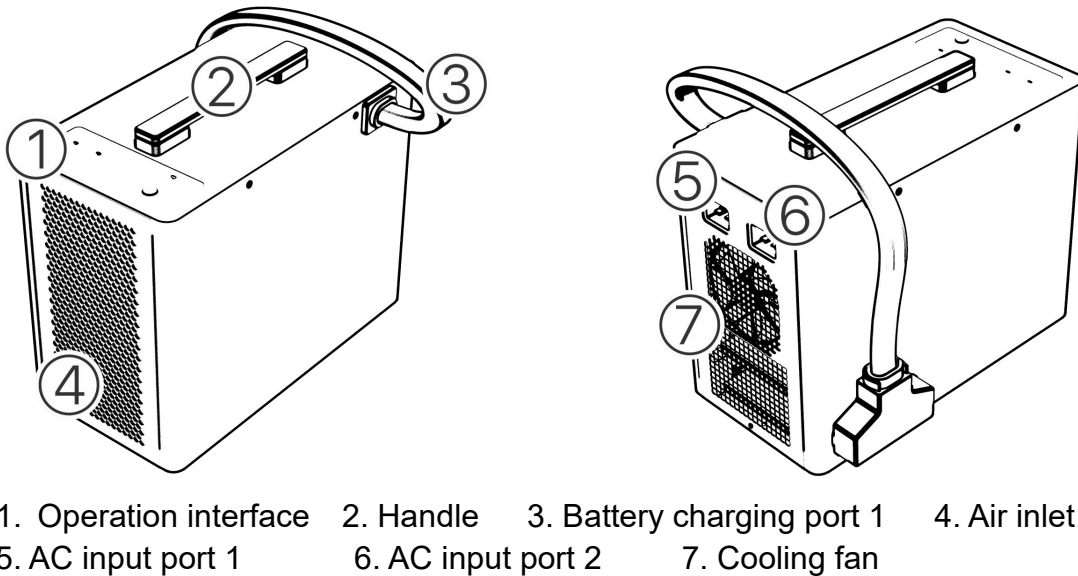
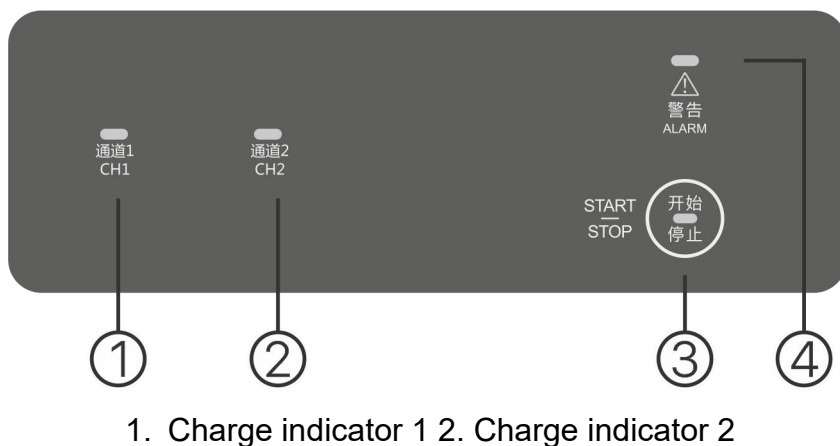

Figure 1-3-1 Charger Components



3. Power on/off button 4. Operating indicator  
Figure 1-3-2 The Operation Panel

### 1.3.2. Function Description

#### 1.3.2.1. Status Indicator LED Description

##### 1) Activation Indicator Description

The charger needs to be activated at the first usage. After the charger is connected to the drone via Bluetooth, please activate it according to the APP guidance.

| Status      | Prompt | Battery channel status indicator | Alarm indicator | Operating indicator |
|-------------|--------|----------------------------------|-----------------|---------------------|
| Deactivated | /      | Solid White                      | Solid White     | FLASH               |
| Activated   | /      | OFF                              | OFF             | FLASH               |

##### 2) Self-check

First, make sure that all the terminals are correctly connected, then press the “start/stop” button on the operational panel. The battery charging status indicator and alarm indicator will turn white. The charger will complete the self-check with a beep sound at the end.

##### 3) Charging Logic

The charger will charge one battery at a time, according to the remaining capacity from high to low.

##### 4) Description of the Battery Charging Status Indicator

| LED flash rules | Warning | Description  | Notes |
|-----------------|---------|--|-------|
| OFF             | /       | No battery connected to the corresponding port                           |       |
| Yellow Solid On | /       | The battery is connected to the corresponding port, waiting for charging |       |

|                                |          |  |   |
|--------------------------------|----------|--|---|
| Green Breathing                | /        | The corresponding port is in slow charging mode                      |   |
| Green Fast Flash               | /        | The corresponding port is in fast charging mode                      |   |
| Green Solid On                 | /        | The battery connected to the corresponding port is fully charged     |   |
| Yellow Continuous              | /        | Battery temperature is too low. The charging current is limited      | $0 \leq \text{Cell temperature} < 10^{\circ}\text{C}$         |
| Yellow Continuous              | /        | Battery temperature is too low. Charging is prohibited.              | Cell temperature $< 0^{\circ}\text{C}$                        |
| Yellow Continuous Triple Flash | /        | Battery temperature is too high. Charging is prohibited.             | Cell temperature $> 65^{\circ}\text{C}$                       |
| Red Single Flash               | D.D.D... | The battery is not plugged in/unofficial battery/communication error |   |
| Red Double Flash               | D.D.D... | Batteries of different voltages are mixed charged                    |   |
| Red Triple Flash               | D.D.D... | BMS error  | For troubleshooting, check the charging permission conditions |
| Red Solid On                   | D.D.D... | Output over-voltage. other hardware error                            |   |

| LED Flash Rules      | Warning | Description                     | Action                 |
|----------------------|---------|---------------------------------|------------------------|
| All On, Then All Off | D       | Self-check is completed         |                        |
| Yellow Single Flash  | /       | Charger temperature is too high | Self-directed derating |

|                     |          |   |                        |
|---------------------|----------|---|------------------------|
| Yellow Double Flash | /        | Input voltage is under voltage                            | Self-directed derating |
| Yellow Triple Flash | /        | Input voltage is high                                     | Charge normally        |
| Red Signal Flash    | D.D.D... | Ambient temperature is too high or fan malfunction        | Stop charging          |
| Red Double Flash    | D.D.D... | Fault in charger input voltage (Under-voltage protection) | Stop charging          |
| Red Triple Flash    | D.D.D... | Fault in charger input voltage (Over-voltage protection)  | Stop charging          |
| Blue Solid On       | /        | Only one power module is working                          | /                      |

### 1.3.3. Charge Steps

**Step 1:** Insert the power cable to the charger's power port, and insert the other connector to the AC power supply (200-240V, 50/60Hz)

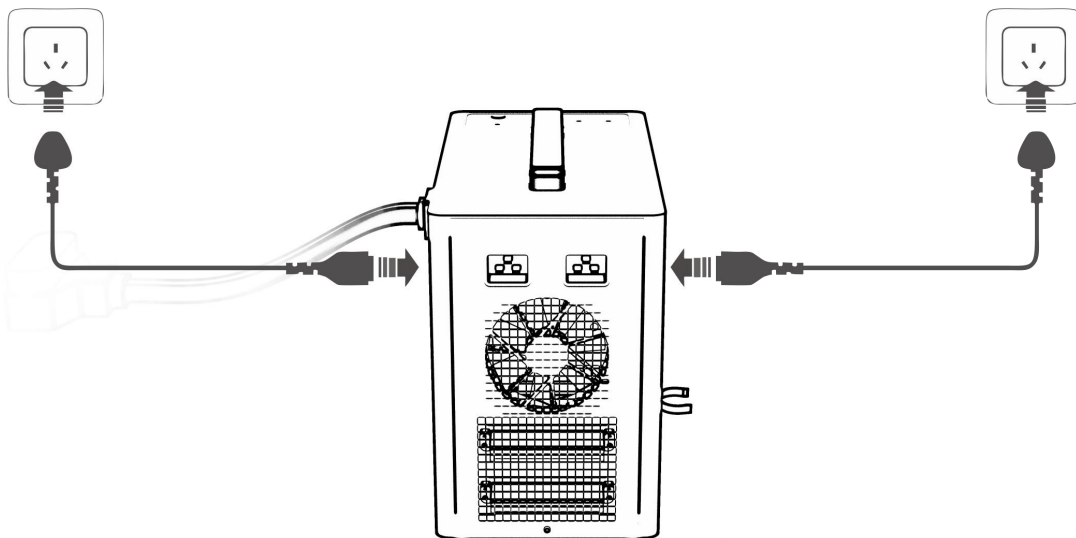

Figure 1-3-3 Charger Power Cable Connect

**Step 2:** Connect the charger: connect the charger adapter cable to the charger charging port.

**Step 3:** Connect the battery: connect the charger adapter cable to the battery

charging port as shown in the figure below. Please make the "△" sign face outwards. See Figure 1-3-4.

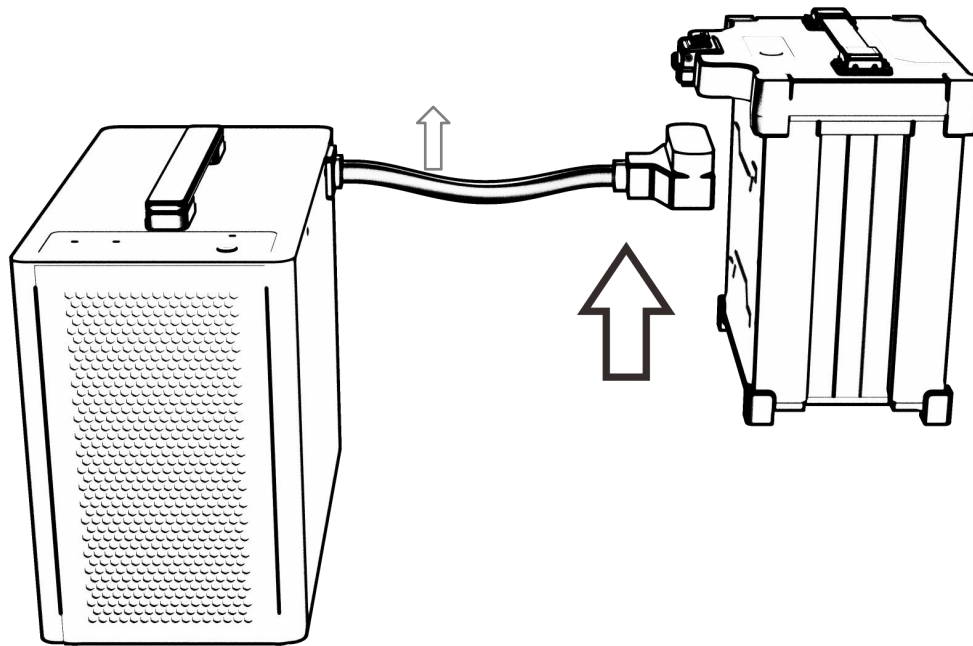
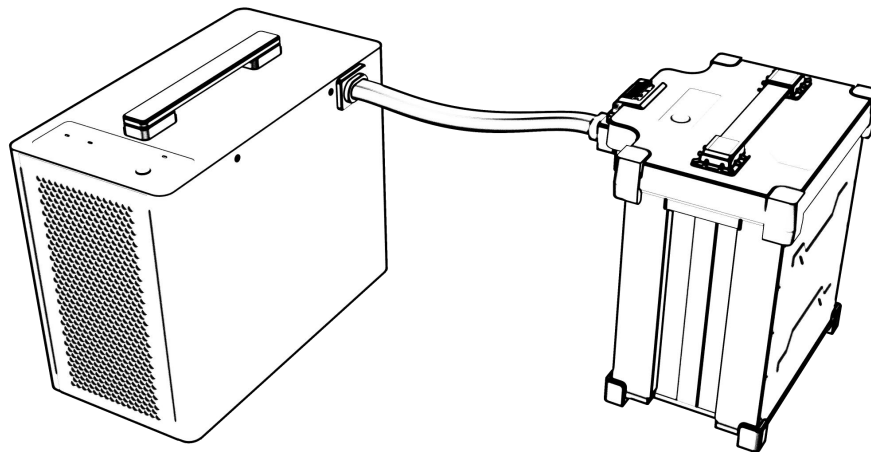

Figure 1-3-4 Battery Connect



**Step 4:** After making sure that all wires are connected correctly, press the “Start/Stop” button in the operation panel, and the charger will start self-check. If a battery is connected, the indicator light of the corresponding channel will be solid yellow. The alarm indicator is off when the self-check is completed. If the error occurs, please refer to the description section of the indicator state.

**Step 5:** Working mode selection: after the self-check is completed, the charger defaults to fast charging mode. You can select fast charging mode or slow



charging mode by pressing the button.

**Step 6:** Press the "Start/Stop" button in the operation panel to turn off the battery after charging, unplug the AC power cable, and unplug the battery. Please follow the rules below.

| Charging Mode | Battery State        | Channel Indicator State                     | Plug or Unplug Battery Instruction   |
|---------------|----------------------|---|--|
| Fast Charging | Fully charged        | Corresponding channel light is solid green  | Unplug battery directly  |
|               | Waiting for charging | Corresponding channel light is solid yellow | Unplug battery directly  |
|               | Charging             | Corresponding channel light flashes green   | If plugging or unplugging is needed, please press the start/stop button first. Plugging or unplugging directly is prohibited |
| Slow Charging | Fully charged        | Corresponding channel light is solid green  | Unplug battery directly. After plugging or unplugging, the charger will reorder the batteries                                |
|               | Waiting for charging | Corresponding channel light is solid yellow | Unplug battery directly. After plugging or unplugging, the charger will reorder the batteries                                |
|               | Charging             | Corresponding channel light green flash     | If plugging or unplugging is needed, please press the start/stop button first. Plugging or unplugging directly is prohibited |

**Notes:**

1. Make sure the charger is grounded before use.
2. Do not use the product in direct sunlight, high humidity, high temperature, dust, vibration or thunder/lightening.
3. Products should be kept away from dangerous substances such as high pressure, heat source, corrosive agent, flammable gas, etc., and must be used at appropriate ambient temperature (5-45°C is recommended).
4. Products should be placed in a stable horizontal position, and good ventilation and heat dissipation conditions should be ensured when working.
5. When charging, please strictly follow the battery safety instructions and cautions.
6. Before connection, please ensure that all ports and input lines of modules and batteries have no obvious defects such as blockage, damage,

breakage or short circuit.

7. Before use, please ensure that the power supply line has enough capacity to avoid overheating or even fire caused by insufficient capacity, especially when two or more pieces of equipment are used at the same time.
8. Do not pull out the input wire when the charger is working. Pull out the battery in time after charging.
9. Make sure the battery is well connected before charging.
10. This charger is only applicable to the battery of this drone. If the user uses the charger for purposes other than those listed in the manual, the Company shall not assume any responsibility.
11. Do not leave the charger unattended when it's working. If any function is not normal, please stop charging immediately.
12. In case of fire, do not use liquid extinguisher to avoid electric shock. Use dry powder extinguisher correctly.

#### 1.3.4. Specification Parameters

| Subject               | Parameter  |
|-----------------------|--|
| Input                 | AC 220-240V 50/60Hz  |
| Rated Input Voltage   | AC 220V/ 50~60Hz   |
| Output Power          | max 7200W  |
| Output Voltage        | max 58.8V  |
| Charging Current      | max 150A (Adjustable)  |
| Operating Temperature | 5°C~45°C   |
| Operating Humidity    | 0%~75%   |
| Storage Temperature   | -10°C~70°C   |
| Storage Humidity      | 0%~75%   |
| Voltage Detection     | Support  |
| Protection            | Over-current protection<br>Over-temperature protection<br>Over-voltage protection<br>Short circuit protection<br>Reverse connection protection |
| Weight                | 11.8kg   |
| Dimension             | 330*170*280mm  |

### 1.4. Drone Introduction

#### 1.4.1. Functional Features

3WWDZ-30.1 Agricultural plant protection drone has the following features:

1. Made of professional carbon fibers with lighter weight and higher strength.

Foldable arms are designed for easy transportation.

2. Swappable tank and battery make mode changing easier, and also improve the efficiency.
3. With a high-precision GNSS navigation system and IMU sensor, the drone has an accurate positioning function to ensure safety and reliability.
4. Dual water pumps are equipped and each has an independent control spraying system. Flowmeter is provided to ensure high precision of spraying and good atomization effect.
5. The Agriculture Assistant APP supports smart route planning so that the drone can operate autonomously. It helps to make the pilot's work easier.
6. No waste gas emits so the drone is environmentally friendly and meets the government's requirements for energy conservation, environmental protection and the development of a "green agriculture". It is also easy to maintain, and cost-effective.

#### 1.4.2. Drone Components

Drone components are shown in the figure below.

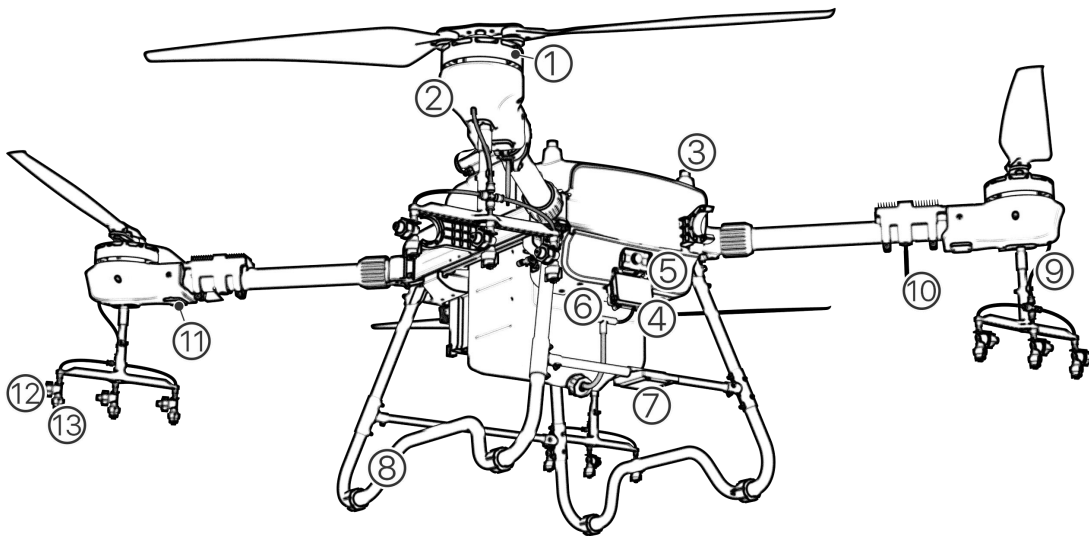

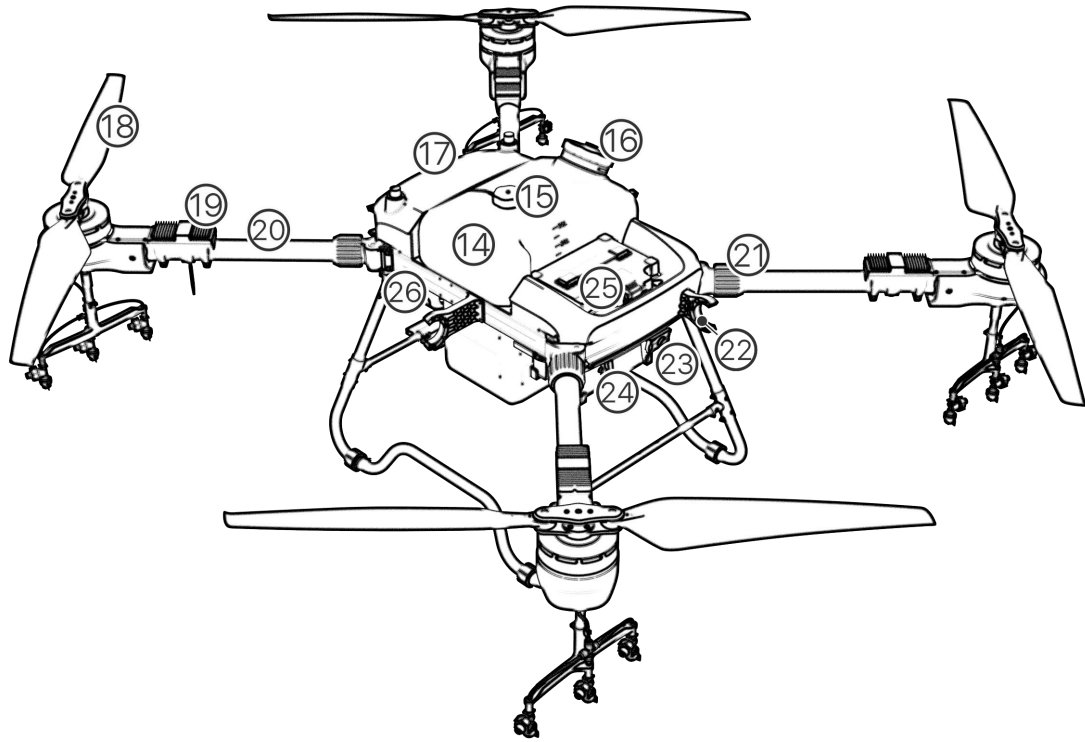

|                     |                     |                            |                                   |
|---------------------|---------------------|----------------------------|-----------------------------------|
| 1. Motor            | 2. Motor Cover      | 3. RTK Antenna             | 4. Front Obstacle Avoidance Radar |
| 5. Front FPV Camera | 6. Pump             | 7. Terrain Following Radar | 8. Landing Gear                   |
| 9. Pipe             | 10. Antenna         | 11. Status Indicator       | 12. Nozzle                        |
| 13. Nozzle Tips     | 14. Tank            | 15. Continuous Level Meter | 16. Tank Inlet                    |
| 17. Head Direction  | 18. Propeller       | 19. ESC                    | 20. Arm                           |
| 21. Arm Sleeves     | 22. Clamping Unit   | 23. Rear FPV Camera        | 24. Rear Obstacle Avoidance Radar |
| 25. Super Battery   | 26. Drone Nameplate |                            |                                   |

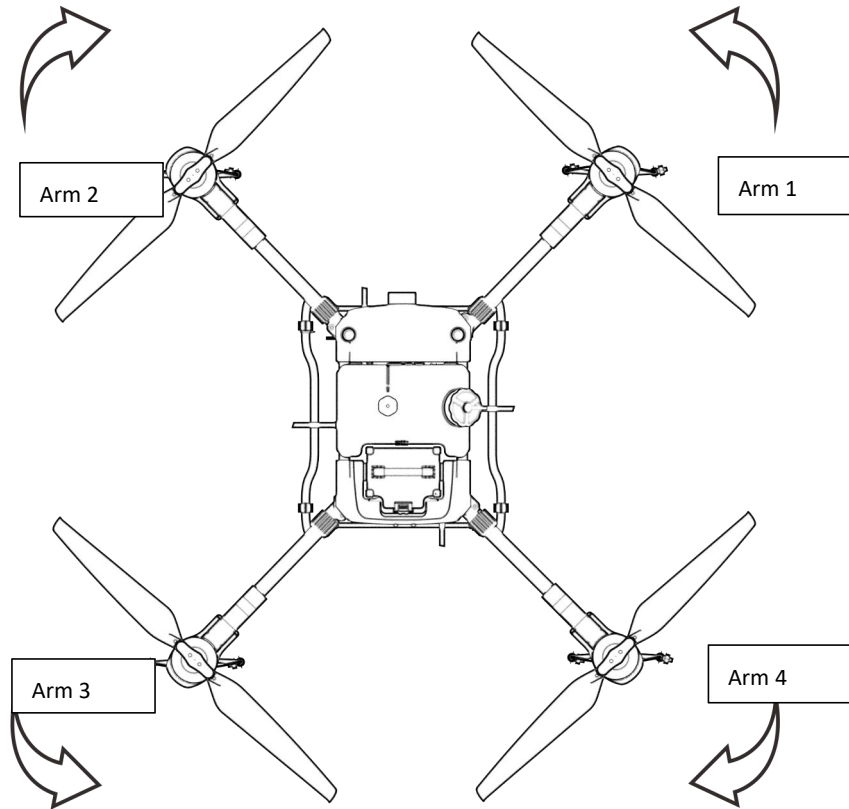

Figure 1-4-2  
Head Direction

**Notes:**

The propellers on arm 1 and arm 3 rotate counterclockwise, while on arm 2 and arm 4 rotate clockwise. See Figure 1-4-2.

**1.4.3. Preparation**

**1.4.3.1. Unfold Arms**

**Step 1:** Take 3WWDZ-30.1 plant protection drone out of the box.

**Step 2:** Horizontally rotate the propellers to remove them from the holder.

**Step 3:** Unfold the arms. See Figure 1-4-3.

**Step 4:** Tighten the arm sleeves as shown in Figure 1-4-4.

**Step 5:** Unfold the propellers to 180°, as shown in Figure 1-4-5.

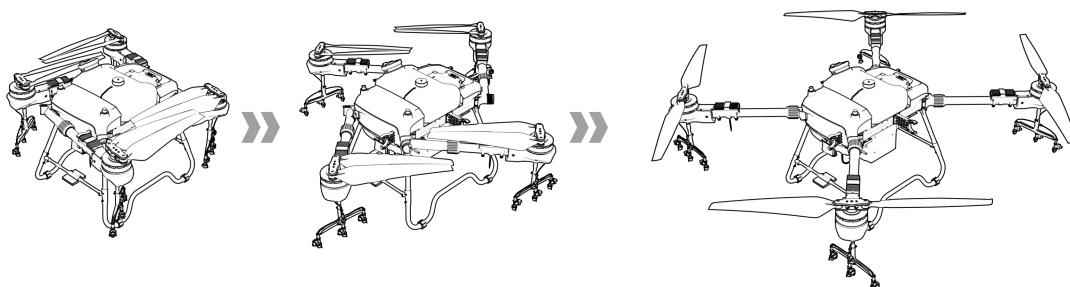

Figure 1-4-3 Arms Folded

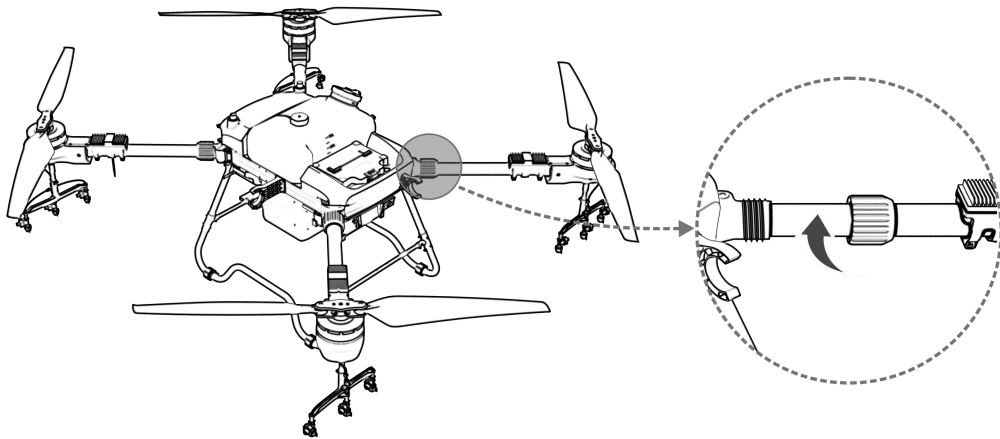

Figure 1-4-4 Arms Unfolded

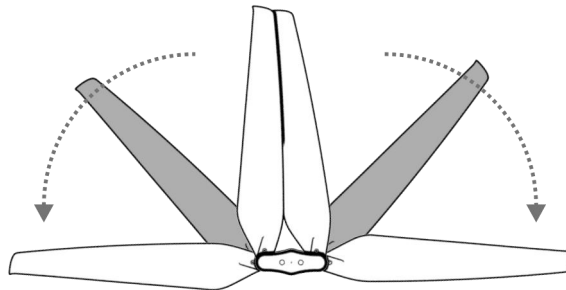

Figure 1-4-5 Unfold the Propellers

**Notes:**

The arm sleeves is a pinch point. Be careful with your hands.

**1.4.4. Install Battery**

Be sure to use the official battery and check the battery level before flying.

**Step 1:** Place the battery vertically down in the battery rail on the rear side of the drone body.

**Step 2:** Connect the battery output port to the body, and the battery is locked in when you hear a “click”. See Figure 1-4-6.

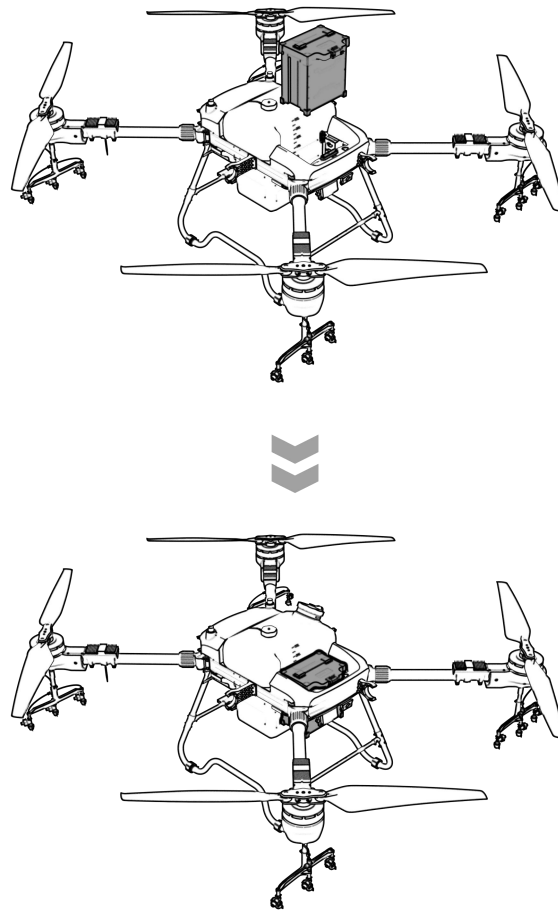

Figure 1-4-6

## 1.4.5. Equipment Calibration

### 1.4.5.1. Compass Calibration

**Method 1: Access the calibration function via APP installed on the RC:**

**Step 1:** Pull down the throttle.

**Step 2:** Quickly toggle down "Flight Mode Switch" to the down position ("S") and toggle it up to the up position ("G") for about 6-10 cycles until the status indicator light flashes blue.

**Step 3:** Place the drone head forward and keep the drone level with the ground. Slowly rotate the drone clockwise for at least one circle. If the status indicator flashes green, process to step 4. If the status indicator is solid green, the calibration is completed.

**Step 4:** Lift the drone horizontally for more than 45° to the ground. Slowly rotate the drone clockwise for at least one circle until the status indicator shows solid green for 4s. The calibration is completed.

**Step 5:** Calibration fails if the status indicator shows solid red for 4s. Repeat

Step 2-4 until the operation succeeds. See Figure 1-4-7.

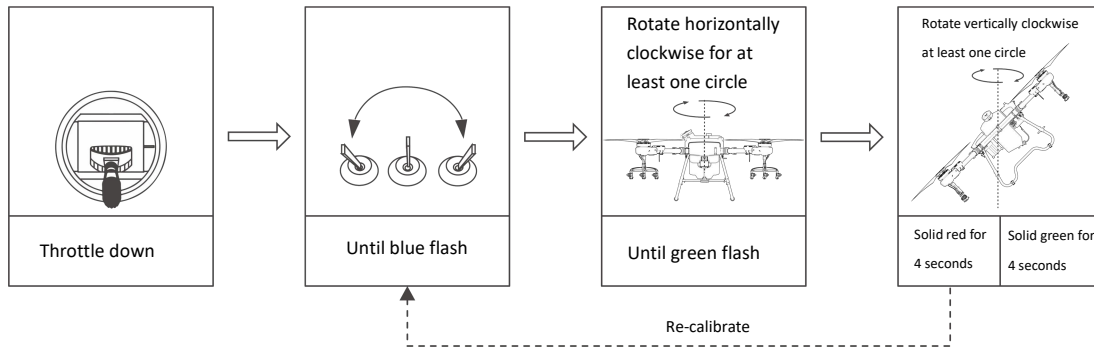
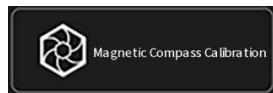

Figure 1-4-7 Compass Calibration

**Method 2: Enter the calibration function via APP:**

**Step 1:** Click on the right top in the APP to enter the Setting interface, and click into Flight Setting.



**Step 2:** Click to enter the magnetic compass calibration interface. Click to start the calibration, and the drone navigation light flashes blue.

**Step 3:** Repeat the Step 3-5 in Method 1.

**Notes:**

1. Before calibration, the propellers on the drone should be removed.
2. Do not calibrate it in areas with strong magnetic fields, such as magnetic mines, parking lots, building areas with underground steel reinforcement, etc.
3. During the calibration, do not carry ferromagnetic materials, such as keys, mobile phones, etc.
4. Do not calibrate the compass indoors.

**1.4.5.2. Flowmeter Calibration**

Flowmeter calibration must be performed when the drone is used for spraying for the first time, otherwise, the operation effect will be affected.

Preparation before calibration : Press button to start the pump when the drone is on the ground to discharge the air from the pipeline.

**Step 1:** Add about 5000ml liquid into the tank.

**Step 2:** Enter the Setting interface, and click “Flowmeter Calibration”.

**Step 3:** Plan a regular-shaped field, no less than 0.34 hectares. The length



Level".

**Step 4:** Upload the flight route, and start the operation until the liquid runs out and the breakpoint is recorded.

**Step 5:** After the drone returns, the APP will pop up the dialog box of "Sprayed Volume".

**Step 6:** Input "5000ml" in the "Spray Volume" dialog box.

**Step 7:** The calibration is completed.

**Notes:**

1. Re-calibrate after replacing with different nozzles.
2. Re-calibrate after replacing agrochemical with different viscosity.
3. Re-calibrate if the error between the actual operation area and theoretical operation area is more than 10%.

## **2. Flight**

### **2.1. Flight Instructions**

According to the regulations of the International Civil Aviation Organization (ICAO) and national air traffic control on airspace control and the regulation of drones, drones must fly in the prescribed airspace. For flight safety, the flight restriction function (including altitude and distance restrictions and no-fly area) is enabled by default to help users to use the product safely and legally.

When GNSS is available, the no-fly area affects the flight together with altitude and distance restriction. The drone flyable airspace is the intersection of restricted airspace. Without GNSS, the drone flight height is not limited by Agriculture Assistant APP.

#### **2.1.1. Altitude and Distance Restriction**

Height limit is used to limit the flight height of a drone and maximum radius is used to limit the flight distance of an aircraft. The maximum flying altitude of the drone on delivery is 20 meters. See Figure 2-1-1.

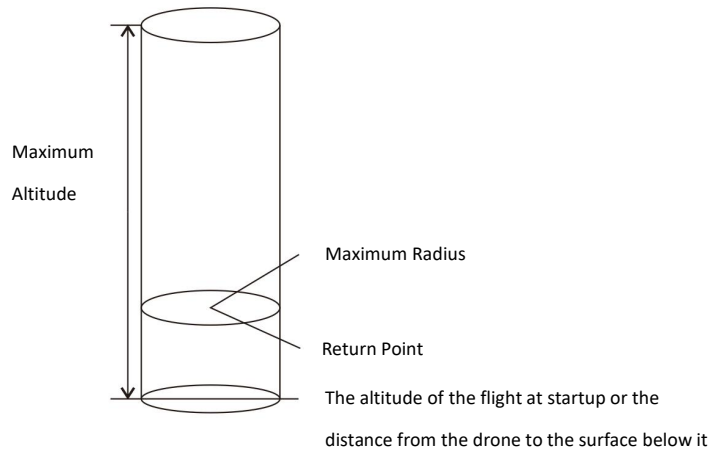

Figure 2-1-1 Altitude and Distance Restriction

| <b>GNSS State</b>   | <b>Flight Mode</b>           | <b>Flight Limit</b> |          | <b>Notification</b>                           |
|---------------------|------------------------------|---------------------|----------|---|
| <b>With GNSS</b>    | GPS mode and autonomous mode | Max Altitude        | 20m      | Warning                                       |
|                     |                              | Max Radius          | 9999m    | Warning                                       |
|                     | Attitude mode                | Max Altitude        | 20m      | Automatically switch to GPS mode with warning |
|                     |                              | Max Radius          | 9999m    | Automatically switch to GPS mode with warning |
| <b>Without GNSS</b> | Attitude mode                | Max Altitude        | No limit | No warning                                    |
|                     |                              | Max Radius          | No limit | No warning                                    |

## 2.1.2. No-Fly Zone and Restricted Area

### 2.1.2.1. No-Fly Zone

The area includes airport restricted flight areas and special flight restricted areas. For more details, please refer to special flight restricted areas defined by local authorities.

### 2.1.2.2. Restricted Area (when GNSS is available)

Areas are temporary restricted for flying due to emergencies (such as forest fires, large-scale events, etc.). The restricted area can be a circle or a polygon. The drone is not allowed to fly within the no-fly zone. See Figure 2-1-2.

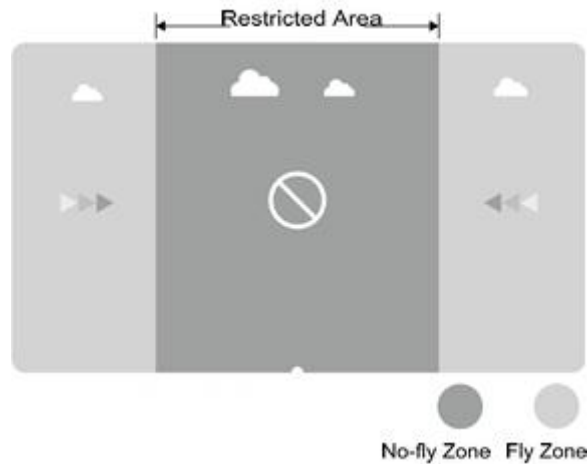

Figure 2-1-2

| GNSS signal is normal |   |   |
|-----------------------|---|---|
| Area                  | Special Area with Flight Restriction  | Status Indicator Light for the Drone    |
| No-fly Zone           | The motors can not be activated.<br>If the drone flies without GNSS, it will land automatically immediately after GNSS is available, and the motor stops automatically after landing. | Red light solid on for 5s and off in 1s |
| Close to No-fly Zone  | Distance to the no-fly zone <120m.<br>The drone flight speed will slow down with flashing lights and alarming.  | Red light solid on for 5s and off in 1s |
| Fly Zone              | The drone can fly normally. No flight restrictions.   | No Warning                              |

**Notes:**

For flight safety, please try to avoid airports, highways, railway stations, subway stations or urban areas. If users need to fly in such areas, prepare relevant materials and apply for temporary airspace to local authorities. Then contact the after-sales service to release the restriction.

**2.2. Indicator Description**

On the first test flight, it is recommended to understand the meaning of the flight status indicators to ensure a safe flight.

| No. | Status | Content  | Indicator Display      |
|-----|--------|--|------------------------|
| 1   | Normal | Power on<br>Self-check is completed<br>GPS satellite searching | Flash yellow for twice |

|    |          |   |   |
|----|----------|---|---|
| 2  |          | Preparation is completed;<br>waiting for take-off | Solid yellow  |
| 3  |          | Taking-off and flying                             | Head direction, solid red;<br>Opposite head direction,<br>solid green |
| 4  |          | Mode switch                                       | Flash green for 5s  |
| 5  |          | Magnetic compass calibration<br>(Horizontal)      | The indicator flashes<br>yellow twice per second                      |
| 6  |          | Magnetic compass calibration<br>(Vertical)        | The indicator flashes<br>green twice per second                       |
| 7  |          | Magnetic compass calibration<br>succeeds          | Solid green for 4s  |
| 8  | Abnormal | Magnetic compass calibration<br>failure           | Solid red for 4s  |
| 9  |          | Self-check Failed                                 | Solid red   |
| 10 |          | Low Voltage/Volume Level I                        | Flash red slowly  |
| 11 |          | Low Voltage/Volume Level II                       | Solid red   |
| 12 |          | IMU failure                                       | Solid red   |
| 13 |          | Barometer failure                                 | Solid red   |
| 14 |          | GPS failure                                       | Solid red   |
| 15 |          | Independent magnetic compass<br>failure           | Solid red   |
| 16 |          | Motor failure                                     | Solid red   |
| 17 |          | RC lose control                                   | Solid red   |

## 2.3. Operation Description

### 2.3.1. Pre-flight Inspection

Please check the following points to avoid flight accidents.

1. Place the drone in the open operation area and the user should face the tail.
2. Make sure that the battery of the drone is installed properly.
3. Before flying, it is necessary to turn on the remote controller before plugging in the battery of the drone.
4. Ensure the battery of the drone and the remote controller are adequately charged, also the agrochemical required for spraying is sufficient.
5. Make sure that the motors and propellers rotate in the correct direction and the structure is stable. All arms and propellers of the drone have been fully extended, and the arm sleeves have been tightened.
6. Make sure that the spraying pipes are free of blockage and leakage, and the nozzles can spray water normally. If there is no liquid sprayed out

during spraying test, please turn on the pressure relief valve on the side of the nozzles manually. After discharging the air, turn off the pressure relief valve, and the nozzles can be used for operation.

### 2.3.2. Lock and Unlock

#### 2.3.2.1. Unlock

The unlocking operation is shown in Figure 2-3-1. When you unlock the drone, the motors rotate in the sequence of No. 1, No. 2, No. 3 and No. 4. When motor No. 1 starts, push the throttle slightly up and all the motors will start at the same time.

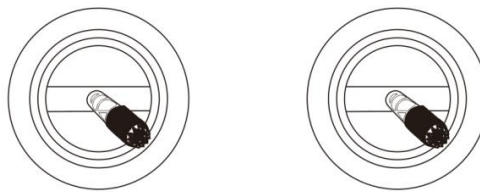

Figure 2-3-1 Unlock

#### 2.3.2.2. Lock

The drone supports two active locking methods:

- Perform the operation shown in Figure 2-3-2 to lock.
- After the drone lands, the throttle stick should be kept at the down position for at least 3s, and then the drone will be locked automatically.

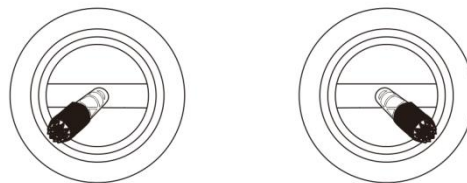



Figure 2-3-2 Lock

### 2.3.3. Take Off and Land

#### 2.3.3.1. Take Off

**Step 1:** Click on “” and then long press “” for 2s to turn on the remote controller.

**Step 2:** Turn on the power supply of the drone.

**Step 3:** The pilot should keep a distance from the drone of more than 10m. Enter the operation interface of the Agriculture Assistant APP to ensure that

the signal of GNSS is good, and the status indicator light of the drone is not showing red, which means there's no warning.

**Step 4:** Perform the unlock action, the drone motors will start one by one, then slowly push up the throttle stick to take off.

**Step 5:** The drone remains at its current altitude and hovers after the throttle lever is centered, as shown in Figure 2-3-3.

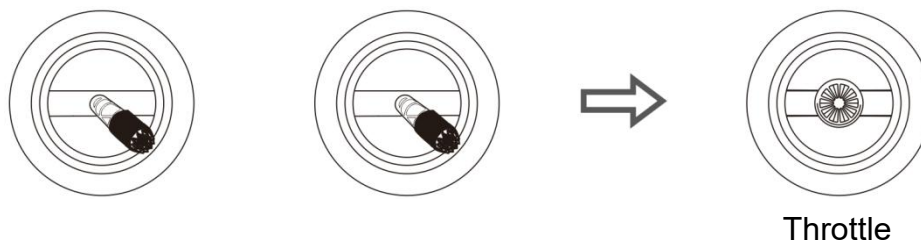

Figure2-3-3 Unlock and Hover

### 2.3.3.2. Land

**Step 1:** Slowly pull down the throttle stick, and the drone lands on the ground.

**Step 2:** After the drone lands, place the throttle stick to the down position, and then perform the locking action as shown in Figure 2-3-4.

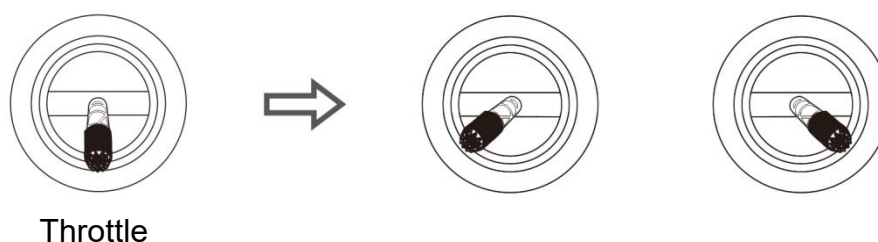

Figure 2-3-4 Land and Lock

#### Notes:

1. For the first test flight, the flight altitude shall not exceed 4m.
2. Do not fly beyond the visual range for the first test flight.
3. If there is light flashing showing an alert or there is a warning on the interface of the Agriculture Assistant APP during the flight, please land immediately and check the drone according to the plant protection assistant warning information.

### 2.3.4. GPS Operating Mode

#### 2.3.4.1. Mode Introduction

GPS operation mode has the features of being easy-to-use and quick-to-start, which is suitable for the operation in small, irregular and complex fields. In GPS mode, the maximum flying speed of the drone is 7m/s. The spraying speed of the liquid is related to the flying speed. The faster the drone flies, the greater the flow rate is. When the drone hovers, the flow shuts down

automatically.

### 2.3.4.2. Operating Procedure

**Step 1:** Before taking off, click “

**Step 2:** The drone takes off and flies to the field for operation.

**Step 3:** Press the spray button “

#### Notes:

During the operation, make sure that the drone is in the visual range.

### 2.3.5. AB Point Mode

#### 2.3.5.1. Mode Introduction

AB point operation mode is suitable for use in the regular area. It has fewer operation steps. In the AB point operation mode, the drone can operate automatically after Point A and Point B are recorded. The spray will turn off automatically when the drone changes lines.

The flight route for AB point operation mode is shown in Figure 2-3-5. The dotted line length is the line spacing, which can be set in Agriculture Assistant APP according to the working conditions.

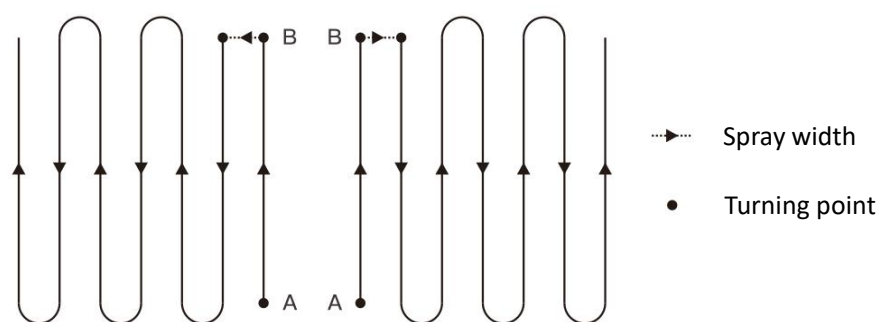

Figure 2-3-5 AB Point Operation Route

#### 2.3.5.2. Operating Procedure

**Step 1:** After the drone taking off, fly the drone to point A of the operating field, and click the “A” Button. The Agriculture Assistant APP will send a voice notification of “Point A is recorded successfully”.

**Step 2:** Fly the drone to the B point of the operating field, and click the “B” Button. The Agriculture Assistant APP will send a voice notification of “Point B is recorded successfully”.

**Step 3:** Click the “AB” Button. The Agriculture Assistant APP will send a voice notification of “AB Point Mode”.

**Step 4:** Toggle the RC stick to the left/right to fly the drone in the direction of the next line and then the drone will perform according to the planned route.

### **2.3.5.3. Exit AB Point Mode**

The drone can exit AB point by the following methods:

1. No liquid is remained, and breakpoint has been generated.
2. Enter Automatic Obstacle Avoidance Hover Mode.
3. Manual emergency brake the drone. The drone will record the breakpoint and hover.
4. During the operation in AB Point Mode, click the “AB” button on the RC (blue light is off) and the drone will exit the AB point operation mode and hover. If the user clicks the “AB” button on the RC again, the drone will fly directly to the breakpoint or projection point and continue the operation. (Returning to the breakpoint or projection point can be set in the Agriculture Assistant APP).

#### **Notes:**

1. During the operation, it is necessary to ensure that the drone is within the visual range.
2. AB points can be recorded when the GNSS signal is strong and there is no breakpoint.
3. The distance between "A" and "B" point should be no less than 10m.
4. During operation, the flight altitude can be adjusted by the RC to meet the actual need. When the throttle is in the central position, the drone will maintain its current altitude.

### **2.3.6. Autonomous Mode**

#### **2.3.6.1. Introduction**

Users can survey the field and mark the obstacle, and set the border point using the field surveying function of the Agriculture Assistant APP. The Agriculture Assistant APP will calculate and generate the best route. This mode is suitable for large or irregular fields. The operation route of fully autonomous operation mode is shown in Figure 2-3-6. The dotted line shows the line spacing. It can be set in the Agriculture Assistant APP.



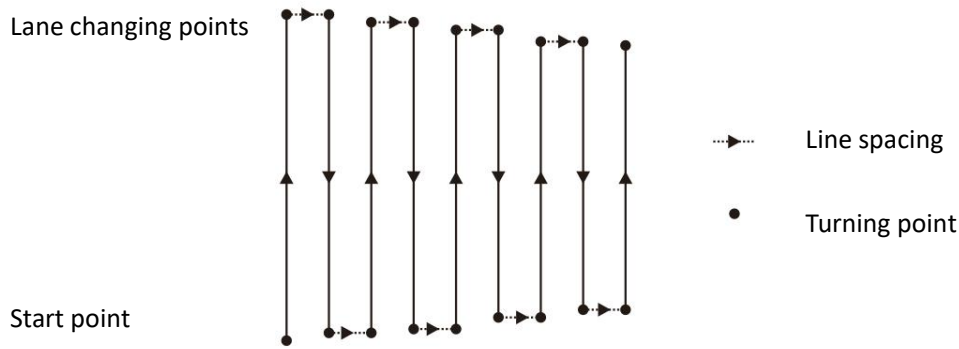

Figure 2-3-6 Auto Operation Route

### 2.3.6.2. Field Surveying Steps

**Step 1:** Run the Agriculture Assistant APP and there will be three options (GPS mapping mode, drone mapping mode and RTK hand-held marker mapping mode), you can choose according to the actual situation.

**Step 2:** Set a name for the field.

**Step 3:** Mark the border points: select the points at each corner of the borderline.

**Step 4:** Mark the obstacle: if there are obstacles in the field, click the obstacle point and select the shape. Click on the turning points of the obstacle shape to set it as an obstacle point, and then click "OK" after the obstacle points setting is completed.

**Step 5:** Calibration point settings: after editing the operation area, calibration points need to be added. Calibration points are used for map rectification. When setting calibration points, make sure the reference object is easy to identify; the surrounding area is clear and suitable for the drone to take off. The operation area setting is completed when the calibration point is set.

### 2.3.6.3. Autonomous Operation Steps

**Step 1:** After the Agriculture Assistant APP is connected to the drone, click to expand the land/task list in the main interface.

**Step 2:** Select a field (or a field in the task list) and click to use the field.

**Step 3:** Place the drone at the calibration point of the operation area, click on "Calibrate", then click "Calibrate Drone Position".

**Step 4:** After the field is chosen, set the following parameters one by one: route angle, turning mode, route inner contraction, obstacle point spacing, altitude, usage per mu, ways of bypassing obstacle area.

**Step 5:** According to the route condition, select the routes ready to be sprayed (all routes are selected by default).

**Step 6:** Click "Start Operation" on the operation interface.

**Step 7:** Slide to unlock (please set the RTH height and take off height), and the drone will take off automatically and execute the planned route.

**Step 8:** Complete the operation (also can be finished manually during operation) and then generate the operation report.

**Notes:**

1. During the operation, it is necessary to ensure that the drone is in the visual range.
2. During the operation, the throttle stick of the RC can be toggled to adjust the flight altitude according to the plant condition. When the throttle stick is in the central position, the drone will resume its setting altitude.
3. For more detailed operation, please refer to the " User Manual of the Agriculture Assistant APP ".

## 2.4. Function Introduction

### 2.4.1. Remaining Liquid

#### 2.4.1.1. Introduction

3WWDZ-30.1 is equipped with a real-time level meter, which can detect the remaining liquid in real-time and display it in percentage to the users, as shown in the figure below. During operation, breakpoints can be selected by combining the remaining liquid and route length. This can reduce the time when drone is flying to the breakpoint and not operating, which will improve the operation efficiency.

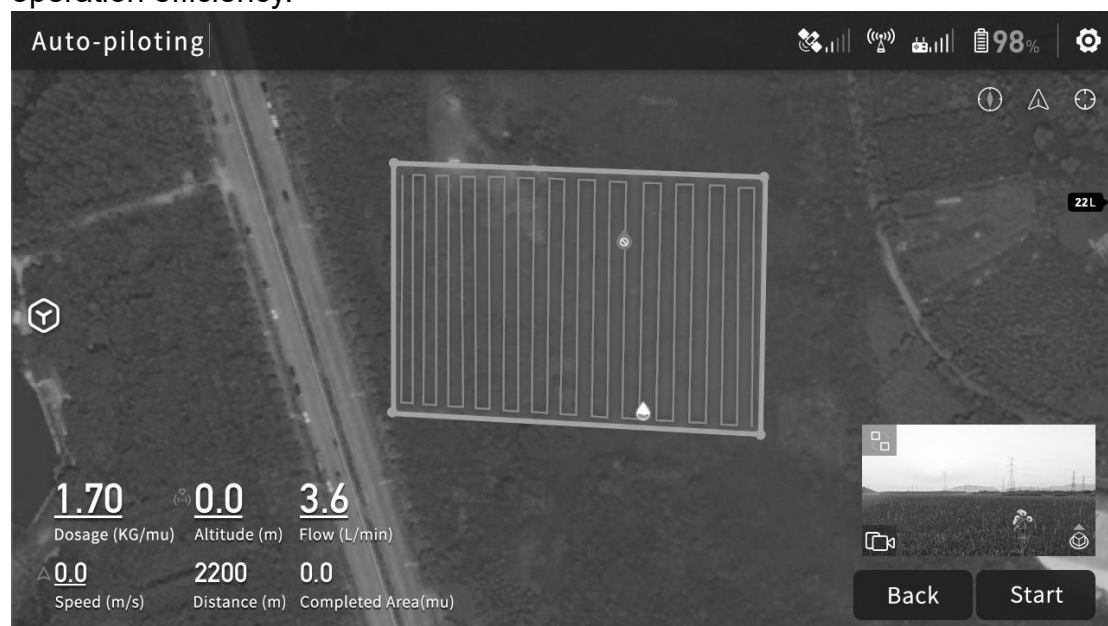

## 2.4.2. Resume at the breakpoint

### 2.4.2.1. Introduction

If the breakpoint is recorded during the operation due to running out of agrochemical, low battery, manual braking, obstacle avoidance, etc., the drone can be set to resume operation at the breakpoint following the established route.

### 2.4.2.2. Record the breakpoint

During the operation, the drone will record the breakpoint and resume the operation at the breakpoint in the following situations:

1. Insufficient liquid in the tank.
2. When the low voltage protection function is enabled and the Level II warning is triggered.
3. Pitch or roll stick on the RC is pulled/pushed.
4. When the drone enters the RTH mode.
5. When the drone has obstacle avoidance radar and has detected the obstacle, which leads to an automatic brake.
6. When the location signal or heading signal is weak, the drone will automatically exit the operation mode and enter the protection mode, and record the current coordinate as the breakpoint.

#### Notes:

1. Any condition above is met, the drone will update the breakpoint.
2. The following actions can be set for the drone according to the operating environment after no remaining liquid: hover, raise 2m and hover, RTH and no action.

### 2.4.2.3. Return to the breakpoint

The steps for returning to the breakpoint are as follows:

**Step 1:** Hover the drone manually in any open place and ensure there is no obstacle between this position and the breakpoint.

**Step 2:** Click "Return to the breakpoint " (click the AB Button or return to the Projection Point) in the Agriculture Assistant APP.

**Step 3:** The drone automatically rises or descends to the operating altitude and returns to the breakpoint.

**Step 4:** Resume the set route and continue the operation.

#### Notes:

For more detailed operation, please refer to the " User Manual of Agriculture Assistant APP".

#### 2.4.2.4. Return to the Projection Point

If there is any obstacle on the way back to the breakpoint, you can choose "Projection Point" to return to avoid the obstacle.

**Step 1:** After the operation is paused, you can fly the drone manually to bypass the obstacle.

**Step 2:** Click "Continue" on the bottom right corner and select "Return to the Projection Point". Three options corresponding to No. 1, 2, and 3 points are marked in the route.



**Step 3:** Click on one of the points, and the drone will fly to the point to continue the operation.

#### 2.4.3. Terrain-following Radar



##### 2.4.3.1. Introduction

The working range of altitude stabilization function of the terrain-following radar is between 1m and 10m. When the terrain-following radar is turned on, the relative height of the drone and the plants can be kept unchanged during the operation. The drone will fly following the terrain to ensure uniformity of the spraying. The pilot can turn on/off this function by pressing the "Radar Button" on the RC.

### 2.4.3.2. Terrain Setting

For both plain and mountainous terrain, the drone adopts different tracking strategies and the user needs to set the simulated scene of the flight according to the actual operating terrain.

Setup procedure:

**Step 1:** Click  at the top right corner enter the setting page, then click  enter the radar setting interface.

**Step 2:** According to the terrain situation, select "plain" or "mountain" on the right side of the column "Terrain Settings".

#### Notes:

1. Radar module housing should not be crushed causing deformity.
2. Keep the radar antenna cover clean and wipe the surface regularly with a soft damp cloth depending on the frequency of use.
3. When flying the drone over an object surface with a slope, the correlation between simulated slope and flight speed is shown below:  $10^{\circ}$  ( $<2\text{m/s}$ ),  $6^{\circ}$  ( $<4\text{m/s}$ ), and  $3^{\circ}$  ( $<6\text{m/s}$ ).

### 2.4.4. Low Battery Level Protection

The drone has a low battery level protection function. The user can set the warning threshold, which is the battery level in percentage in the Agriculture Assistant APP. When the value is reached, the drone will act according to the setting. The action can be set as: hover, land, return, no action (warning prompt only).

#### 2.4.4.1. Level I Protection

As the Level I protection, the drone indicators flash red. The protection will be triggered after the indicators flash for 10s. The factory default Level I low power threshold is 30%, and the protective action is "no action". At the same time, the Agriculture Assistant APP sends voice notification "Level I Low Battery".

#### 2.4.4.2. Level II Protection

As the Level II protection, the drone indicators flash red. The protection will be triggered after the indicators flash for 10s. The factory default Level II low power threshold is 10%, and the protective action is "auto-landing". At the same time, the Agriculture Assistant APP sends voice notification "Level II Low Battery".

**Notes:**

1. When Level I warning occurs, fly the drone to the safe area and land as soon as possible.
2. It is necessary to avoid the Level II warning as much as possible to avoid accidents.
3. After the low battery protection action is triggered, the drone can only be switched to attitude mode or RTH mode.
4. When the drone lands automatically, the protection mode can be quitted by switching to attitude mode.

**2.4.5. Lost Control Protection****2.4.5.1. Overview of Return to Home (RTH) Mode**

When the GPS signal reaches the seven satellites for the first time during taking-off or flight and the signal quality is good, the drone will record the current location as the RTH point. The process of the drone returning automatically to the RTH point is called RTH.

**2.4.5.2. Protection Logic**

When the drone is in good GNSS signal, the compass work normally, and the RTH point has been successfully recorded. If the RC signal is lost for any reason during the operation, the protection action will be triggered. The protection actions include landing, hovering and RTH.

**Notes:**

1. When the RC is well connected, RTH can be canceled by toggling the RC switch to "S", and the drone can be controlled manually.
2. When the RC is well connected, RTH can be canceled by long-pressing the "" button for 2s.

**2.4.6. Front and Rear Obstacle Avoidance**

The drone is equipped with a new 77GHz millimeter wave radar for obstacle detection, which is unaffected by ambient light and dust. When the working conditions are met, the radar can detect the obstacles in front of and behind the drone. The maximum detection distance can be up to 40m. When obstacles are detected, the drone self-brake to ensure safety during the operation. The obstacle avoidance function is enabled by default and can be turned off in the Agriculture Assistant APP.

### 2.4.6.1. Detection Range

The detection range of the radar module is shown in the following figures. The vertical direction is  $0^{\circ}$  to  $15^{\circ}$  (see Figure 2-4-1) and the horizontal direction is  $\pm 60^{\circ}$  (See Figure 2-4-2). If any obstacle is beyond the detection range, the radar module cannot detect it so the pilot should operate carefully. If an obstacle suddenly appears in the detection area, the radar module needs 0.6s to detect and track the movement of the target.

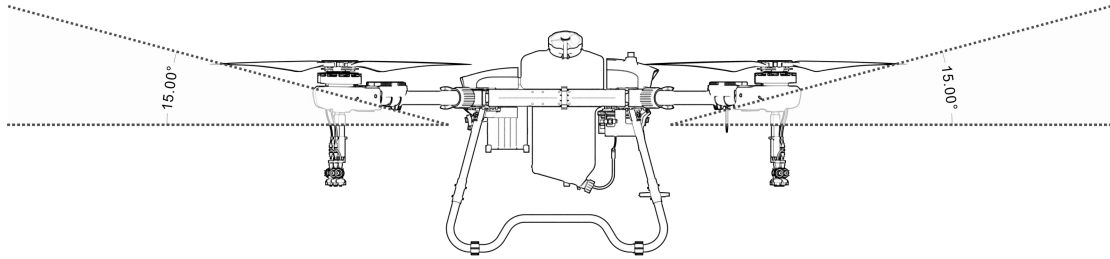

Figure 2-4-1 Vertical View

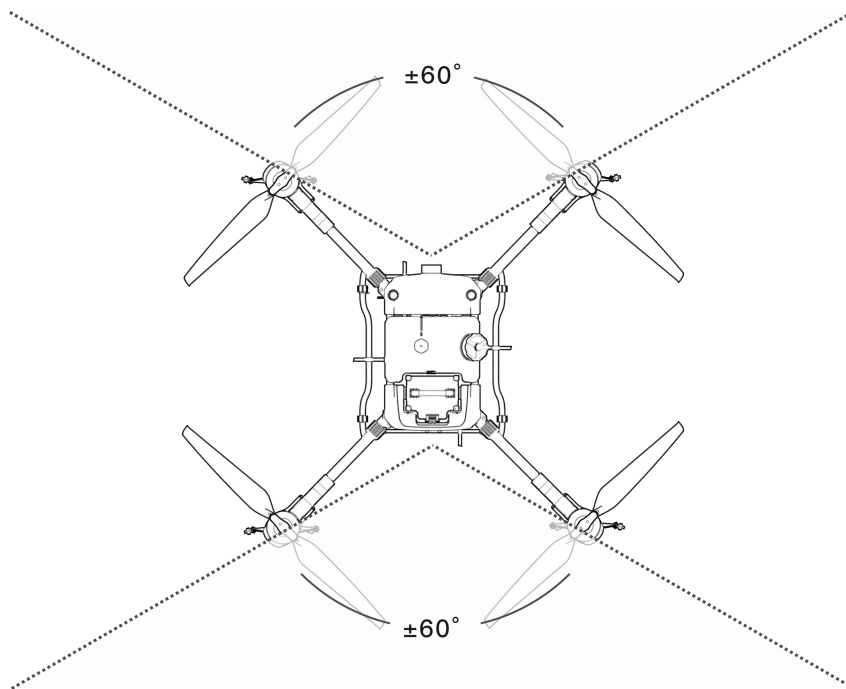

Figure 2-4-2 Horizontal View

### 2.4.6.2. Status Description

The distance between drone and the obstacle is X

| Status 1            | Status 2                           | Status 3        |
|---------------------|------------------------------------|-----------------|
| $X \geq 20\text{m}$ | $20\text{m} \geq X \geq 8\text{m}$ | $X < 8\text{m}$ |

**Status 1:** When the obstacle distance  $\geq 20\text{m}$ , the drone will not brake and the APP will not display any warning.

**Status 2:** Entering the yellow warning zone, the drone slows down to  $2\text{m/s}$  and maintain it. The APP will show the distance between the drone and the obstacle in the yellow zone.

**Status 3:** Entering the red warning zone, the drone will brake urgently and enter the Safe Mode. In the Safe Mode, the drone will remain to hover and cannot be operated to fly towards the direction of the obstacle. The APP will display the obstacle distance in the red zone. Flying the drone to the opposite direction of the obstacle will exit the safe mode.

#### **Special Condition:**

If any obstacle appears suddenly during the flight, the drone will stop with maximum braking force.

#### **2.4.6.3. Obstacle Circumvent**

Equipped with industry-leading vehicle-level radar, which ensures good spatial perception capabilities. When the drone encounters obstacles, it will circumvent obstacles without manual operation.

- Activate method: Switch on the "Obstacle Circumvent" on the radar setting page (default closed) in the Agriculture Assistant APP.

#### **2.4.6.4. Notification**

1. When the obstacle avoidance function is turned on, the obstacle function will not be activated if the drone is in "S" flight mode or the drone is landing.
2. After the obstacle avoidance function is turned on, to ensure sufficient braking distance, the maximum flying speed is  $8\text{m/s}$ .
3. The obstacles can not be detected when the vertical FOV is greater than  $15^\circ$  or less than  $-15^\circ$ .
4. If the front obstacle distance is less than  $8\text{m}$ , the drone will be braked immediately and enter Safe Mode. The drone cannot be controlled to fly forward or turn left/right. The restriction can be released when toggling the stick in the opposite direction.
5. The obstacle avoidance function will not be activated during taking-off, landing or line changing.
6. When the obstacle disappears, the drone will be in the protection mode for  $2\text{s}$ , after which it will gradually lift the speed limit.



### 2.4.6.5. Description of Typical Obstacle Avoidance Scenarios

**Trees, poles:** obstacle avoidance radar can detect the obstacle within 25m, and continuously show warning with the distance. When the distance is less than 20m, the drone will brake automatically to ensure safety.

**Wires:** Taking the 1.5-cm-diameter wire as an example, as the reflection of the wire is poor, the radar is able to detect the wire 13m away while the drone is flying right towards the wire at a speed of 3m/s. The thinner the wire or the higher the flight speed is, the poorer the obstacle avoidance effect will be.

**Notes:**

1. When using the radar module, follow the local radio regulations and legal requirements.
2. For obstacles of different sizes and materials, the effective working range of the radar module will vary. For example, when detecting pedestrian, power cables, dry branches or conifers, the effective detection distance will decrease. Please operate carefully.
3. Radar modules are suitable for flat terrain and may cause false alarms when the slop angle is large.
4. When the surface beneath the drone is less than 1.5m, it is prone to cause false alarms.
5. Never disassemble the radar module by yourself. Otherwise, the improper installation might cause malfunction of the radar.
6. Do not crush or squeeze the housing of the radar module.
7. Radar modules can be used normally on rainy days, and radar detection performance might decrease by 10-20%.

### 2.4.7. RTK Function

#### 2.4.7.1. Introduction

RTK can achieve centimeter-level positioning accuracy to improve the accuracy and reliability of agricultural plant protection. When RTK is activated and the GNSS signal is good, the drone will start the dual antenna direction finding function, which not only has high directional accuracy but also serve as a double backup with the magnetic compass orientation function.

#### 2.4.7.2. RTK Airborne Terminal Setting

RTK services can be obtained by:

**Step 1:** Set the base station to base station mode according to 2.4.7.3.

**Step 2:** Click on the satellite status in the top menu bar of the main interface to enter the RTK setup interface.

**Step 3:** Set the data source to "Datalink". After connecting to the base station successfully, you can view the RTK status. Wait for the display to show "Fixed Solution" and then you can start the operation.

### 2.4.7.3. RTK Base Station Setting

**Step 1:** Turn on the base station and wait until RTK is connecting to the satellites.

**Step 2:** Click the satellite status in the top bar of the main interface to enter the RTK setting interface.

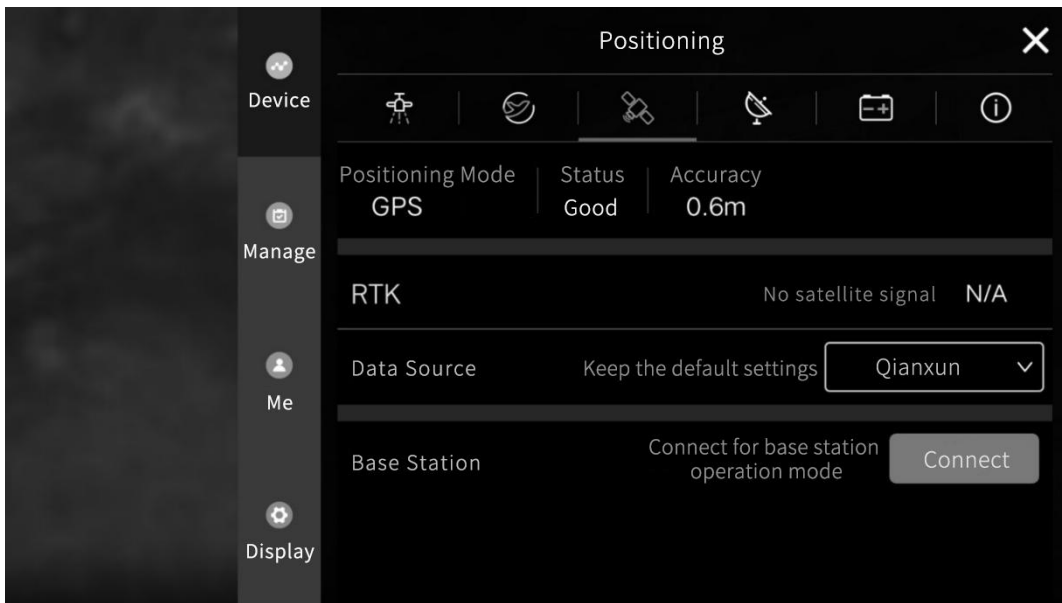

**Step 3:** Click the connection button in the status bar of the base station and select the Bluetooth address of the corresponding RTK base station.

**Step 4:** After successful connection, click the configuration button to choose either of the following two modes:

- A. Marking mode: accurately map of the plot;
- B. Base station mode: provide precise positioning service for the drone in operation.

**Step 5:** After selecting the mode, the RTK system can work normally when "Fixed" is displayed.

#### Notes :

1. Please make sure the base station is level to the ground when setting it up and make sure that the location is higher than the plants in the operating area.
2. Do not move the base station when the drone is in operation.
3. To ensure the signal quality, it is suggested that the antenna of the base station point to the sky and keep perpendicular to the ground.

4. To ensure the communication quality between the base station and the drone, there must be no obstruction between them.

### **3. Maintenance and Common Troubleshooting**

#### **3.1. RC Maintenance & Precaution**

1. The RC needs to be wiped regularly to keep it clean. Keep the RC from water, agrochemical and dust.
2. Please fold the antenna after use to avoid damage.
3. If the drone cannot hover and keeps flying in one direction when the control stick is at the neutral position, the control stick of the RC needs to be calibrated.

#### **3.2. Drone Maintenance & Precaution**

1. Delicate electronic components are inside the drone. Do not soak the drone in water when cleaning.
2. Regular inspection of components is required. Make sure the screws are fastened at all the joints.
3. During transportation, make sure to properly fold the arms so that the motor base is placed on the folding structure.
4. If the structural parts (such as frames, arms, landing gears) are damaged, please contact the after-sales service for replacement.

#### **3.3. Motor Maintenance & Precaution**

The working environment of agricultural plant protection drones' motor is harsh. Water mist, liquid and agrochemical residue are the main factors causing damage. Therefore, it is necessary to:

1. Clean the housing of the motor with a warm cloth after the operation. Remove the residue on the surface, and do not flush the inside of the motor with high-pressure water. Prevent water from leaking into the motor, which will shorten the service life.
2. Check the motor regularly. When the resistance of the motor is high, the sound is abnormal or the gap between the motor and the motor base becomes large, please contact after-sales immediately and maintain according to the instructions by the after-sales.

#### **3.4. Propeller Maintenance & Precaution**

1. If the propeller cracks or is damaged, please replace it in time. Otherwise, it will not have enough lifting power and the drone will be unstable, which will cause safety problems.
2. Pay attention to the marking on the propellers when installing them. Motor No.1 and No.3 should match "CCW" propellers, and motor No.2 and No.4 should match "CW" propellers.
3. Clean up agrochemical residues after finishing the operation.

4. Insert the propeller into the propeller holder during transportation.

### 3.5. Battery Maintenance & Precaution

#### 3.5.1. UPS

##### 3.5.1.1. Specification Parameters

| No. | Project                   | Specification Parameters         |
|-----|---------------------------|----------------------------------|
| 1   | Cell Type                 | Rechargeable Lithium-Ion Battery |
| 2   | Individual Cell Voltage   | 11.1V                            |
| 3   | Capacity                  | 2500mAh                          |
| 4   | Discharge                 | -20°C~55°C                       |
| 5   | Charge                    | 0°C~45°C                         |
| 6   | Storage (Within 3 Months) | -5°C~35°C                        |

##### 3.5.1.2. Notes

1. When the agricultural drone is not used for a period of time, please connect the drone to the battery once a month for no less than 20min, in order to prevent the battery from discharging.
2. Do not disassemble the battery.
3. It is strictly forbidden to throw the battery into the fire, otherwise, it may explode.
4. Batteries should not be immersed in liquids such as freshwater, seawater, beverages, etc.
5. Using damaged batteries are prohibited.

#### 3.5.2. Battery

1. Charge in the slow charging mode regularly to balance the battery voltage.
2. Avoid charging at a temperature of above 45 °C.
3. If the battery falls from height, it might cause a short circuit or even combustion.
4. Make sure the battery is firmly connected to the drone, otherwise it may affect the performance of the drone.
5. If corrosion or discoloration is found in the battery plug of the drone, wipe it with absolute alcohol in time and contact the after-sales department and follow the instructions.
6. Do not use batteries which have dents, scratches and deformation on the surface. Serious mechanical damage may lead to the risk of short circuits or combustion.

7. Make sure all wires are not damaged. Severely damaged wires may cause short circuits or combustion.

#### **Storage Instructions:**

1. For storage of a large number of batteries, it is recommended to keep 30cm between each storage unit.
2. Please avoid direct sunlight for more than 10min under any storage condition.
3. Battery storage environment should be maintained at room temperature (15°C~35°C). Long-term storage above 35°C will accelerate the aging of the battery. Long-term storage at 0°C~15°C may shorten the service time, but after several times of use at room temperature, the normal condition can be restored.
4. Battery storage should avoid a humid environment. Keep storage environment dry and not ventilated.
5. Battery storage locations should not be places where large items are often moved in and out to prevent accidental collisions.

#### **Transportation Instruction:**

1. It is recommended to use a temperature-resistant or flame-retardant box with a cover to store batteries. It is recommended to use the shockproof and tilt-proof sponge in the original box in other packages.
2. Avoid putting the charging and discharging cables on the edge of the box to prevent accidentally being crushed, otherwise, it will lead to a short circuit when being used.
3. During the operation, if the batteries are placed in a vehicle, ventilation should be guaranteed and avoid direct sunlight. The place exposed to direct sunlight in a sealed vehicle may have a temperature of above 80°C, which may cause the battery to burn.

#### **Emergency Instructions:**

Adequate sand, fire extinguishers, and heat-insulating gloves should be provided in places where batteries are stored, transported, or used.

When smoking and burning of batteries are found, the following measures should be taken immediately:

1. Battery is just starting to smoke (or has a burnt odor): Determine the part where a short circuit happens immediately. Lift the battery handle or charge-discharge cable (with heat-insulating gloves if necessary) and quickly drag the battery into the open room or outdoor. Completely bury the whole battery with sand (the charge-discharge cable needs to be buried in if there is smoking). Be careful to wait until the battery has completely

cooled down before taking it out (otherwise the battery may continue to smoke).

2. Batteries emit heavy smoke: immediately use sand and fire extinguishers to extinguish or bury the burning batteries while relocate the surrounding batteries and other flammable objects. If the surrounding flammable and explosive objects (liquids) cannot be removed, immediately use large quantities of water for rapid fire extinguishing and cooling.
3. Batteries are on fire: immediately use a large amount of water, fire extinguishers and sands to extinguish the fire (disconnect the power supply of surrounding electrical equipment first) while removing the surrounding batteries and other flammable material.

#### **Notes:**

When using fire fighting equipment to extinguish fire, strictly follow the requirements and specifications of the local Fire Fighting authorities.

#### **3.6. Plug Maintenance & Considerations**

1. The plug must be inserted completely when it is connected, otherwise, it will heat the plug and affect flight.
2. The power plug and battery plug should be replaced if they have turned black or sparked.

#### **3.7. Spray System Maintenance & Considerations**

1. Fill the water tank, pipe and nozzle with clean water to clean them when the operation is finished.
2. Avoid mixing herbicides and pesticides, otherwise, it will be harmful to plants.
3. In the case of long-term storage or transportation of the drone, always empty the tank.
4. It is forbidden to run the water pump at high speed on an empty tank for long time.
5. Avoid using powders and high-concentration emulsifiers to avoid blocking the spray pipe.

### **4. Transportation Instructions**

#### **Packaging method:**

The drone will be placed in the package box with flexible supporting material embedded in the package box while shipping.

Package size: 1083mm\*1083mm\*905mm as shown below.

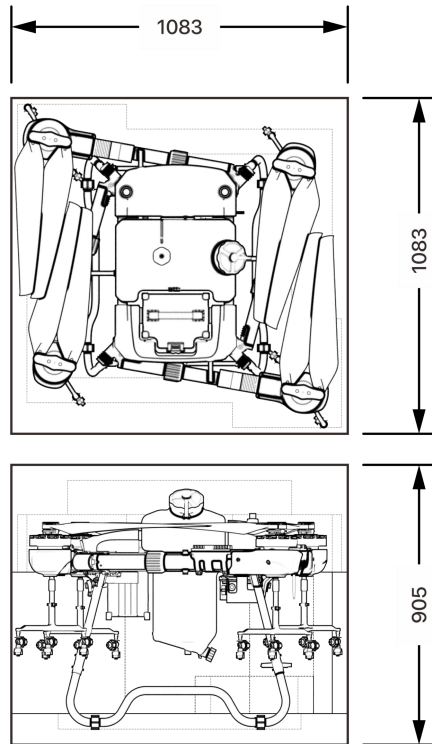

## 5. Hazards and Safety Checklist and Countermeasures

| No. | Hazard                        | Countermeasures  |
|-----|-------------------------------|--|
| 1   | Foldable Structure            | When folding or unfolding the drone, be aware of the hand pinch hazard sign and keep your fingers away from the folding structure.   |
| 2   | High-speed Rotating Propeller | Keep a safe distance from the drone and keep it away from people, animals or other obstacles during operation.   |
| 3   | Charger While Being Charged   | Place in a dedicated charging area and environment. Ensure good ventilation. When the charger is connected to power, make sure the charger is grounded.                    |
| 4   | Tank                          | Flush it with clean water after use and cover it with the lid, and store in a safe place.  |
| 5   | Battery                       | The maximum voltage is up to 51.8V. Please use in strict accordance with the relevant safety regulations and the instructions of the battery, and pay attention to safety. |
| 6   | Agrochemical                  | When handling agrochemical, pay attention to the risk of different kinds of agrochemical. Fully understand the using methods in advance.                                   |
| 7   | During the Operation          | Do not operate in bad weather, such as strong wind (wind speed 8m/s or above), heavy rain (rainfall 25 mm/12 hours or above), snow, fog, etc.                              |

## 6. Manufacturer Information

Manufacturer: Topxgun (Nanjing) Robotics Co., Ltd.

Add.: No.8 Building, Jiyun Building, Jiangsu Software Park, No.1 Dongji Avenue, Jiangning District, Nanjing, China

Tel.: 025-83798727

Website: [www.topxgun.com](http://www.topxgun.com)

## 7. Appendix

### 7.1. Specification Parameters

| Specification              | Parameter   |
|----------------------------|---|
| <b>Package</b>             |   |
| Package Size               | 1083mm*1083mm*905mm   |
| Net Weight                 | 34.6kg  |
| Gross Weight               | 50.2kg  |
| <b>Spraying Mode</b>       |   |
| Dimension (Folded State)   | 1030*1020*788mm   |
| Dimension (Unfolded State) | 2515*1650*788mm (With unfolded propellers)                        |
| Dimension (Unfolded State) | 1650*1480*788mm (Without propellers and nozzle, antenna included) |
| <b>Spreading Mode</b>      |   |
| Dimension (Folded State)   | 1030*1020*896mm   |
| Dimension (Unfolded State) | 2515*1650*896mm (With unfolded propellers)                        |
| Dimension (Unfolded State) | 1650*1480*896mm (Without propellers and nozzle, antenna included) |
| <b>Power Motor</b>         |   |
| Model                      | T13224  |
| Stator Dimensions          | 132mmx24mm  |
| KV                         | 72rpm/V   |
| Power                      | 6000W (1 motor)   |
| Maximum Thrust             | 39.0kg (1 motor)  |



|                           |   |
|---------------------------|---|
| Weight                    | 1980g   |
| Number of motors          | 4   |
| <b>Power ESC</b>          |   |
| Rated Working Current     | 60A   |
| Operating Voltage         | 51.8V ( 14S LiPo )  |
| Maximum Signal Frequency  | 500Hz   |
| Drive PWM Frequency       | 20kHz   |
| <b>Foldable Propeller</b> |   |
| Material                  | Polymer + Carbon fiber                                      |
| Diameter                  | 47inch, 1210mm  |
| Pitch                     | 18inch  |
| Weight                    | 820g  |
| <b>Spraying System</b>    |   |
| <b>Tank</b>               |   |
| Maximum Capacity          | 32L   |
| Rated Capacity            | 30.1L   |
| Weight                    | 2.2kg (Including liquid level sensor and other accessories) |
| <b>Pump</b>               |   |
| Pump Type                 | Diaphragm pump  |
| Max Flow Rate             | 8.0L (1 pump)   |
| Operating Pressure        | 0.2Mpa~0.4Mpa   |
| <b>Nozzles</b>            |   |
| Recommended Model         | 110015VS  |
| Quantity                  | 12  |
| Arm Length                | 1548mm  |
| Maximum Spray Flow Rate   | 8.1L/min (110015VS nozzle, use water as an example)         |
| Spray Range               | 5.0m~8.0m (Depending on the plant)                          |
| Recommended Spray Range   | 7.0m (Operating height: 3m)                                 |

|                                 |  |
|---------------------------------|--|
| Atomization                     | 110015VS : 170μm~265μm (Related to spraying preparation type, spraying flow rate, etc.)      |
| <b>Spreading System</b>         |  |
| Spreader Container              | 45L  |
| Max loading                     | 36kg   |
| Net Wet                         | 5kg (Including weight sensor, spreader container and spreader)                               |
| Feeding Method                  | Rolling feeder   |
| Spreading Method                | Variable air jet   |
| Spreading Range                 | 5.0~7.0m   |
| Operating Temperature           | 0°C~40°C   |
| Dimension                       | 420*355*800mm  |
| <b>Radar System</b>             |  |
| <b>Terrain Following Radar</b>  |  |
| Modulation Mode                 | FMCW   |
| Frequency                       | 76GHz~77GHz  |
| Waterproof Level                | IP67   |
| Height Range                    | 1m~20m   |
| Range Accuracy                  | 0.1m   |
| <b>Obstacle Avoidance Radar</b> |  |
| Detection Range                 | 1m~40m   |
| Using Condition                 | Available in modes other than altitude mode, flight relative height > 1.5m and speed < 6m/s; |
| Safe Distance                   | 4.0m   |
| Avoidance Direction             | Front and rear   |
| Waterproof Level                | IP67   |
| <b>FPV Camera</b>               |  |
| FOV                             | Horizontal 140°, vertical 87°  |
| Resolution Ratio                | 720P   |
| Auxiliary Light Brightness      | 15lux@5m Directly  |
| Auxiliary Light Power           | 6W   |

| <b>Flight Parameter</b>  |   |
|--|---|
| Drone Weight (With Battery)  | 43.6kg  |
| Rated Take Off Weight  | 73.7kg (Spraying State)   |
| Rated Take Off Weight  | 80.6kg (Spreading State)  |
| Maximum Take Off Weight  | 120.8kg (Maximum lift-off weight)   |
| Hover Precision (GNSS signal properly)   | Horizontal $\pm 1.0\text{m}$ , vertical $\pm 0.5\text{ m}$  |
|  | Horizontal $\pm 10\text{ cm}$ , vertical $\pm 10\text{cm}$ (RTK enabled)                              |
|  | Vertical $\pm 0.1\text{m}$ (Radar enabled)  |
| Hover Time*  | > 8min (Take-off weight 73.7kg & 30Ah battery)<br>> 20min (Take-off weight 43.6kg & 30Ah battery)     |
| * The hover time is measured near sea level, when the wind speed is less than 3m/s, and the ambient temperature is 25°C. |   |
| Maximum Flight Speed   | 10m/s   |
| Distance Limit   | 1000m (According to local drone operation laws and regulations)                                       |
| Maximum Take-off Altitude  | 2000m   |
| Recommended Operating Ambient Temperature  | 0°C~40°C  |
| <b>Flight Control System</b>   |   |
| Model  | TIA2022   |
| Input Voltage  | 36.0V~60.9V   |
| Rated Power  | 65W   |
| Working Temperature  | -10°C~60°C  |
| Interface Type   | CANBus, RS485, PWM, USB, etc.   |
| Supported Multi-rotor Aircraft Types   | Four rotors, six rotors, eight rotors (configurable)  |
| Protective Function  | Low voltage protection, lost control protection, no-fly zone protection, etc.                         |
| Supported Languages  | Simplified Chinese/English  |
| <b>Remote Controller</b>   |   |
| Model  | TC1   |
| Operating Frequency  | 2.400GHz~2.4833GHz  |
| Signal Effective Distance (no interference, no obstruction)  | Maximum communication distance: 10km; image transmission distance: 3km (plant protection environment) |

|                                 |  |
|---------------------------------|--|
| Battery Voltage                 | 3.7V (Rechargeable lithium battery)  |
| Battery Capacity                | 12000mAh   |
| Weight                          | 750g   |
| Size                            | 220mm*134mm*43mm   |
| Supported Languages             | Simplified Chinese/English   |
| <b>GNSS System</b>              |  |
| Frequency                       | BDS: B1/B2; GPS: L1/L2; GLONASS: L1/L2;  |
| Hover Accuracy (RMS)            | RTK not enabled:<br>horizontal: $\pm 0.6\text{m}$ , vertical $\pm 0.3\text{ m}$              |
|                                 | RTK enabled (fixed solution):<br>horizontal: $\pm 0.1\text{m}$ , vertical: $\pm 0.1\text{m}$ |
| Orientation Accuracy (RMS)      | 0.4°   |
| <b>Handhold RTK Mapping Kit</b> |  |
| Measurement Accuracy            | Point positioning: 2.0m CEP<br>DGNSS: 0.5m CEP<br>RTK: 2cm+1ppm (horizontal) CEP             |
| Charge Time                     | $\leq 4\text{h}$   |
| Duration                        | Work individually: 8h<br>Work with data transmission: 4h                                     |
| Battery Capacity                | 3000mAh  |
| Waterproof Level                | IP65   |
| Size                            | 70mm*70mm*50mm   |
| Weight                          | 300g   |
| <b>Charger (TC7202)</b>         |  |
| Input Power                     | AC 220V~240V 50/60Hz   |
| Input Voltage Frequency         | 50/60Hz  |
| Output Power                    | DC 58.8V (Max)   |
| Output Current                  | 150A (Max)   |
| Output Power                    | 7200W (Max)  |
| Channel                         | 2 Channels   |
| Supported Language              | Simplified Chinese and English   |
| Net Weight                      | 11.8kg   |
| Gross Weight                    | 12.5kg   |
| Size                            | 330mm*170mm*268mm  |

|                         |  |
|-------------------------|--|
| Package Size            | 440mm*300mm*365mm  |
| <b>Charger (TC7201)</b> |  |
| Input Power             | AC 220V~240V   |
| Input Voltage Frequency | 50/60Hz  |
| Output Power            | DC 58.8V (Max)   |
| Output Current          | 150A (Max)   |
| Output Power            | 7200W (Max)  |
| Channel                 | 1 Channel  |
| Supported Language      | Simplified Chinese and English                             |
| Net Weight              | 11.5kg   |
| Gross Weight            | 12.2kg   |
| Size                    | 330*170*268mm  |
| Package Size            | 440*300*365mm  |
| <b>Battery (TB1430)</b> |  |
| Voltage                 | 51.8V  |
| Capacity                | 30000mAh   |
| Discharge Rate          | 8C   |
| Charge Rate             | 5C   |
| Waterproof Level        | IP56 (when is installed on the drone)                      |
| Battery Life Time       | 1000 cycles (Capacity will be attenuated, no limit to use) |
| Weight                  | 11.1kg   |
| Size                    | 226mm*199mm*269mm  |
| Package Size            | 500mm*300mm*320mm  |